

## ***Standard Specifications***

---

### **High-speed Modular-Type Chip Mounter**

---

Model : Standard Model

CM201-DH: KXF-4V4C

CM202-DH: KXF-4U4C

European Model

CM201-DHU: KXF-4W4C

CM202-DHU: KXF-D24C



Kyushu Matsushita Electric Co., Ltd.

FA Division

# Contents

- 【 1 】 Introduction
- 【 2 】 Features
- 【 3 】 Specification
  - 3 - 1 Equipment specification
  - 3 - 2 Product performance
- 【 4 】 Functions and structure
  - 4 - 1 Feeder table mode
  - 4 - 2 Nozzle
- 【 5 】 Objective workpiece
  - 5 - 1 Chip feeding type
  - 5 - 2 Recognition condition
  - 5 - 3 Range of mount
- 【 6 】 Program data structure
  - 6 - 1 Data structure
- 【 7 】 Basic configuration
  - 7 - 1 Standard machine configuration
  - 7 - 2 Options
- 【 8 】 Others
  - 8 - 1 Safety devices
  - 8 - 2 Machine dimensions
  - 8 - 3 Power and air supply units

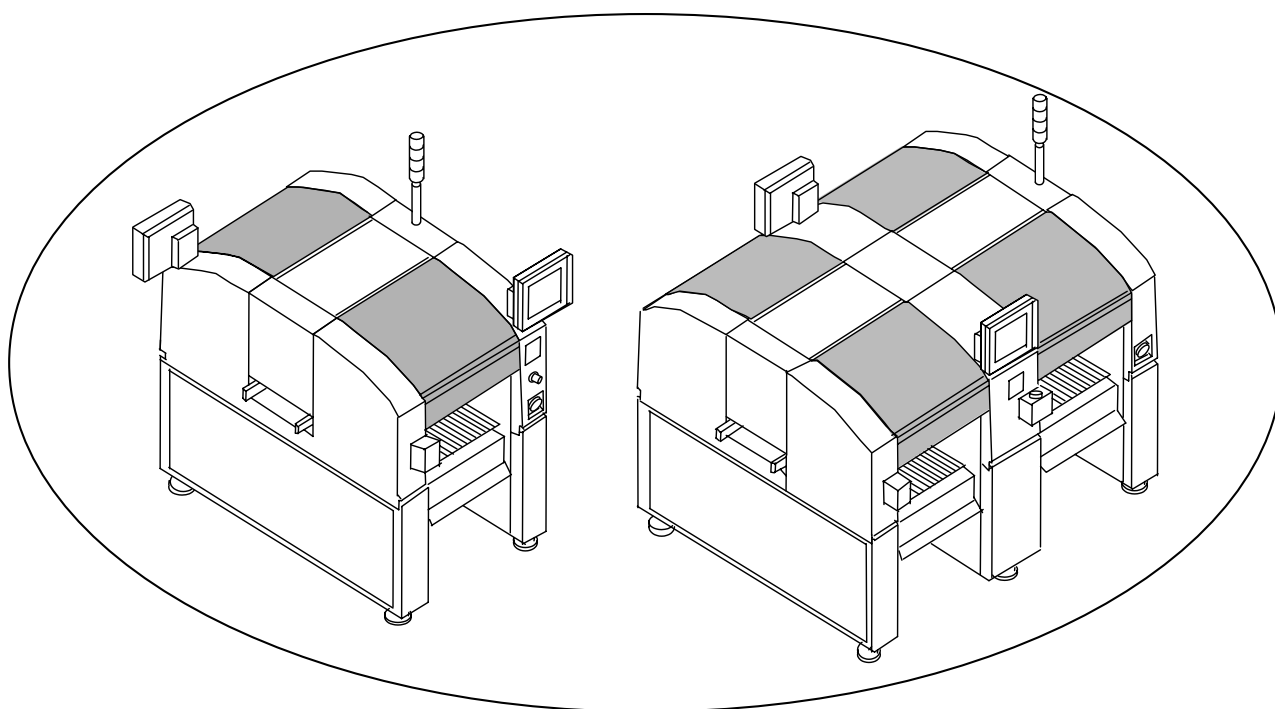

## 【 1 】 Introduction

**CM201-DH/DHU and CM202-DH/DHU** are the high-speed modular-type chip mounter with a new conception which creates the best mounting environment along the production style of users at the small space.

It is possible to change the feeder or machine during the operation.

The batch recognition of all chips makes the high-speed and high-quality mounting possible.

It can use various parts ranging from 0603 (0201") chips to the large parts as PLCC (Max. 24 mm × 24 mm) and also be used for the bump recognition of BGA/CSP as option.

The automatic calibration is substantial and you can always keep the excellent mounting accuracy, without much skill.

The machine has compact and simple structure and you can carry out the maintenance of it very easily.

## 【 2 】 Features

### Improved productivity

#### Multi-head system

It has two of heads, recognition systems, and feeder tables for each mount stage.

Pickup, recognition, and mounting in turn by two heads with the multi-row nozzle (6 nozzles) enables the high-speed and high accuracy mounting.

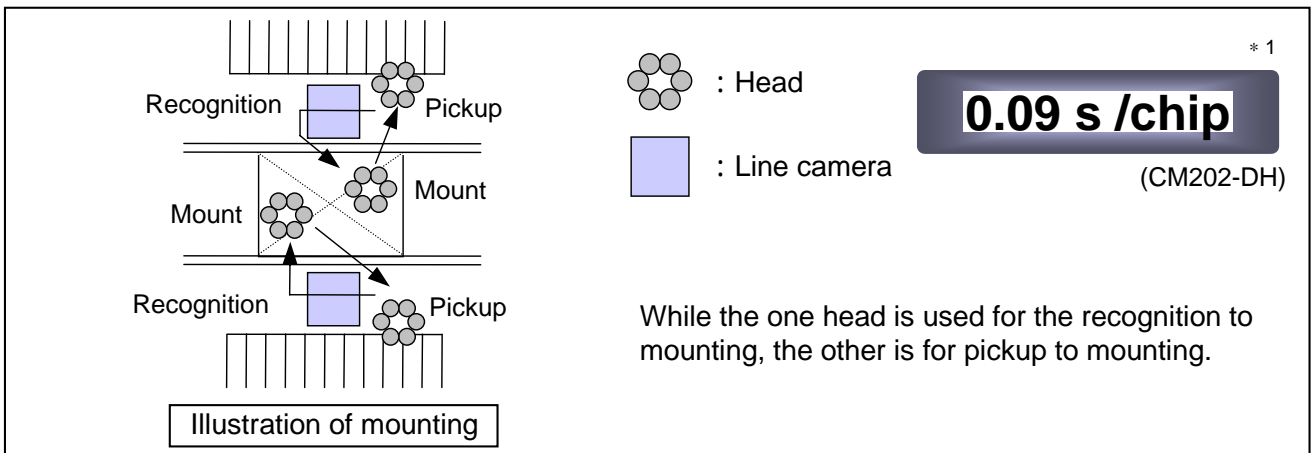

\* 1: As for 0603 (0201") mounting, this will be 0.113 s/chip because of no concurrent pick-up and the low-speed recognition. (CM202-DH)  
 When the 0603 (0201") high-precision mode is used, it will be 0.130 s/chip.(CM202-DH)

#### CM201

Basic machine with a set of multi-head system

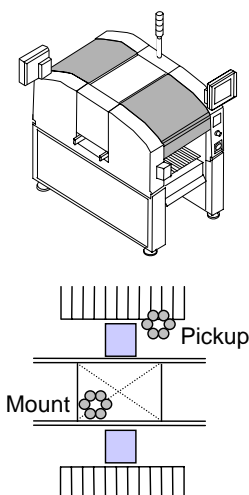

#### CM202

Machine with two sets of multi-head system which mounts two boards once .

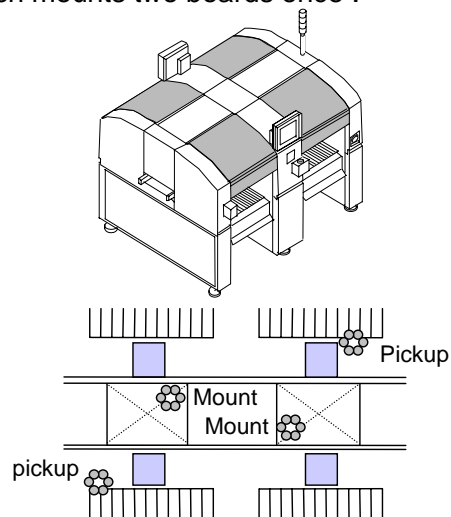

## Application to machine joint (module)

CM201-DH/DHU and CM202-DH/DHU supports coupling (module) and can be coupled with up to 8 stages of one or more machine. \* 1, \* 2

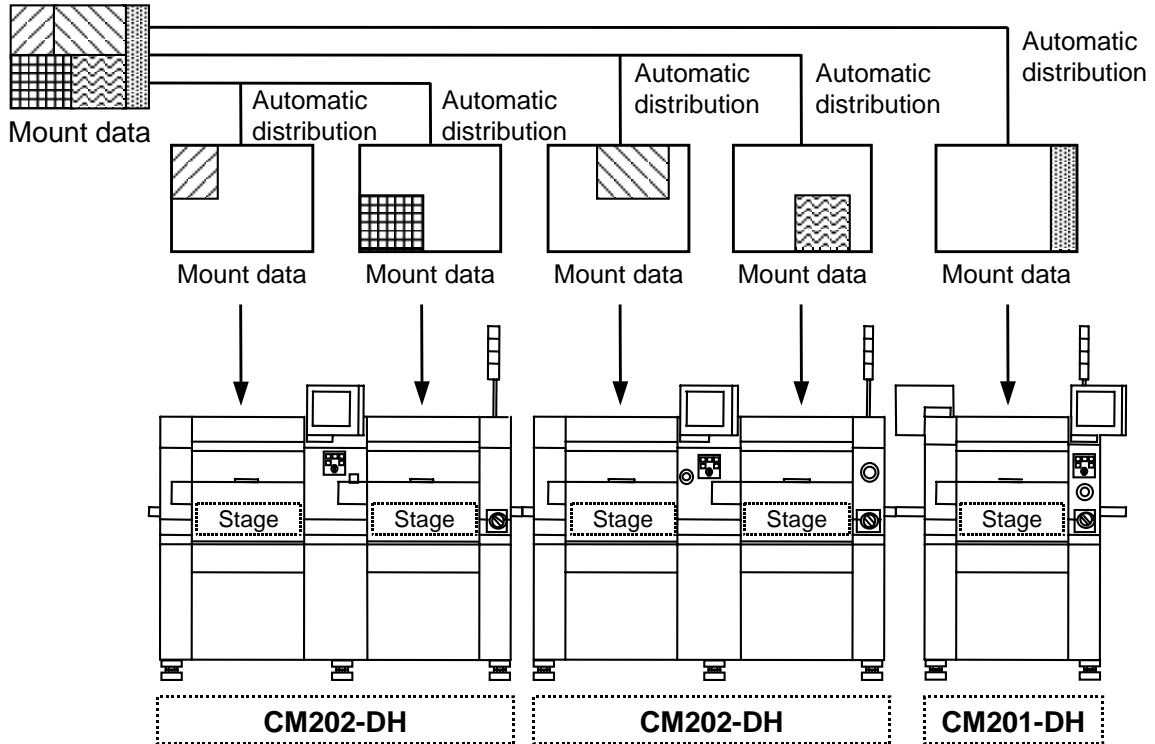

《 Illustration of data distribution of three machines (five stages) of CM202-DH, CM202-DH and CM201-DH 》

## Various types of tapes and much spares

Maximum of 52 tape feeders can be set to CM201 and 104 to CM202. (For the tape width less than 12 mm)

Using the double tape feeder [option] makes the number of set tapes double. (Only the tape of 8 mm width)

Installing the optional unit for bulk feeder [option] enables you to use the bulk feeder.

CM202

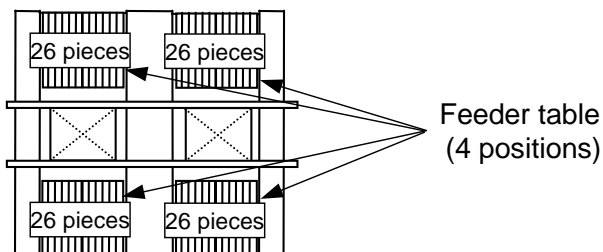

104 tape feeders of 26 at each four position can be set.  
[Among the feeder slots No. 1 to No. 27, No. 14 is missing.]

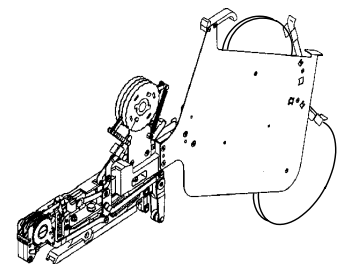

Double tape feeder

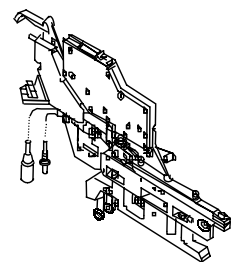

Bulk feeder

## Remarks

- \* 1: Example of joint) When it is configured with only CM202, 4 of them can be jointed at most.
- \* 2: When the machines more than 4 which are jointed with the combination of CM201/202, the switching hub must be installed to the fifth machine and afterward. Make contact with us for details.

### Efficient operation at a small space

Using the multi-head on the downsized body can give high productivity at the small space. The productivity per installation area is 8 700 CPH/m<sup>2</sup> which exceeds much more than the old modular. The new machine gives greatly efficient operation at the small space.

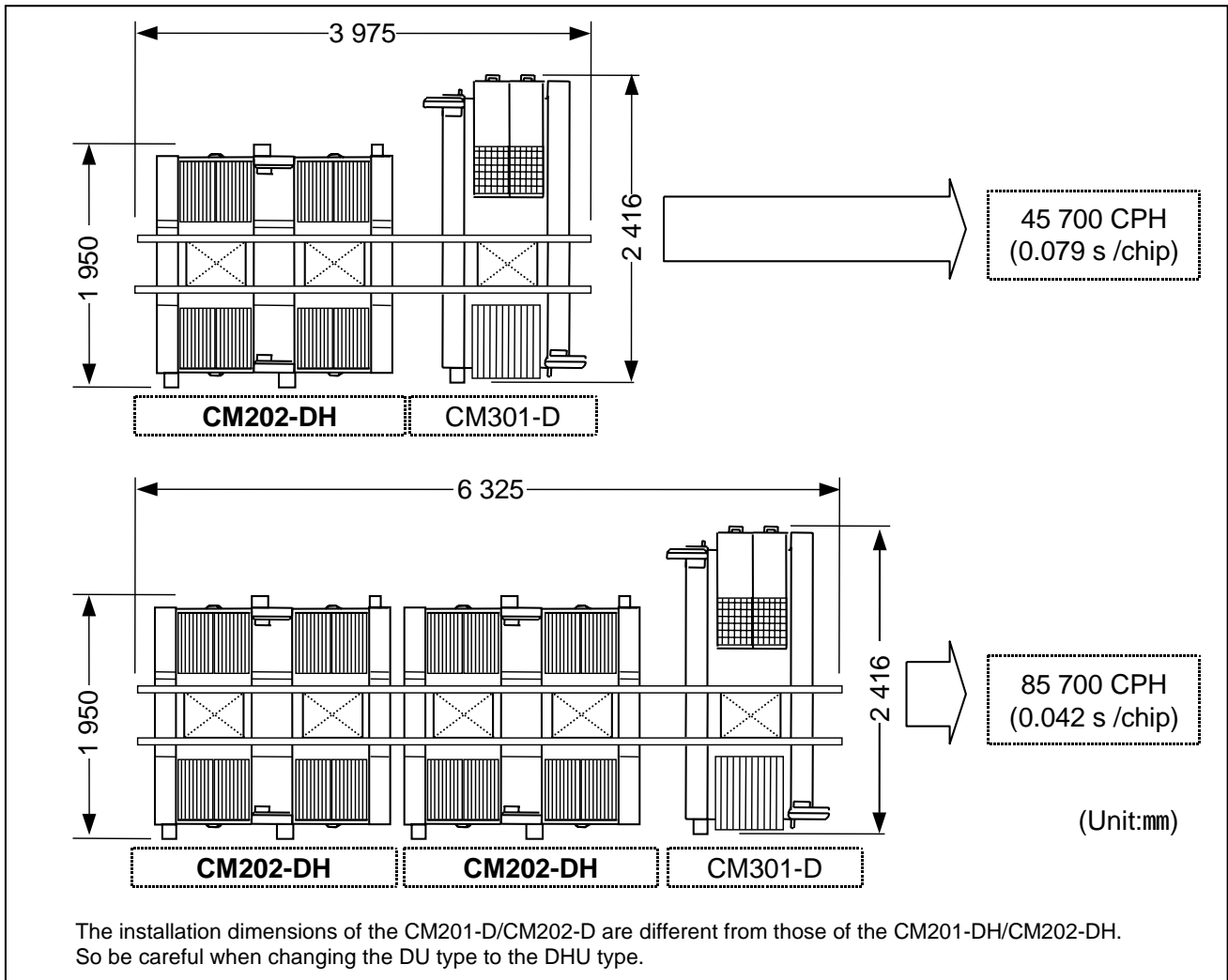

### Double board clamp

When the length of board is 215 mm or less, 2 boards can be clamped on a stage. It shortens the transfer distance of board and the time for it.

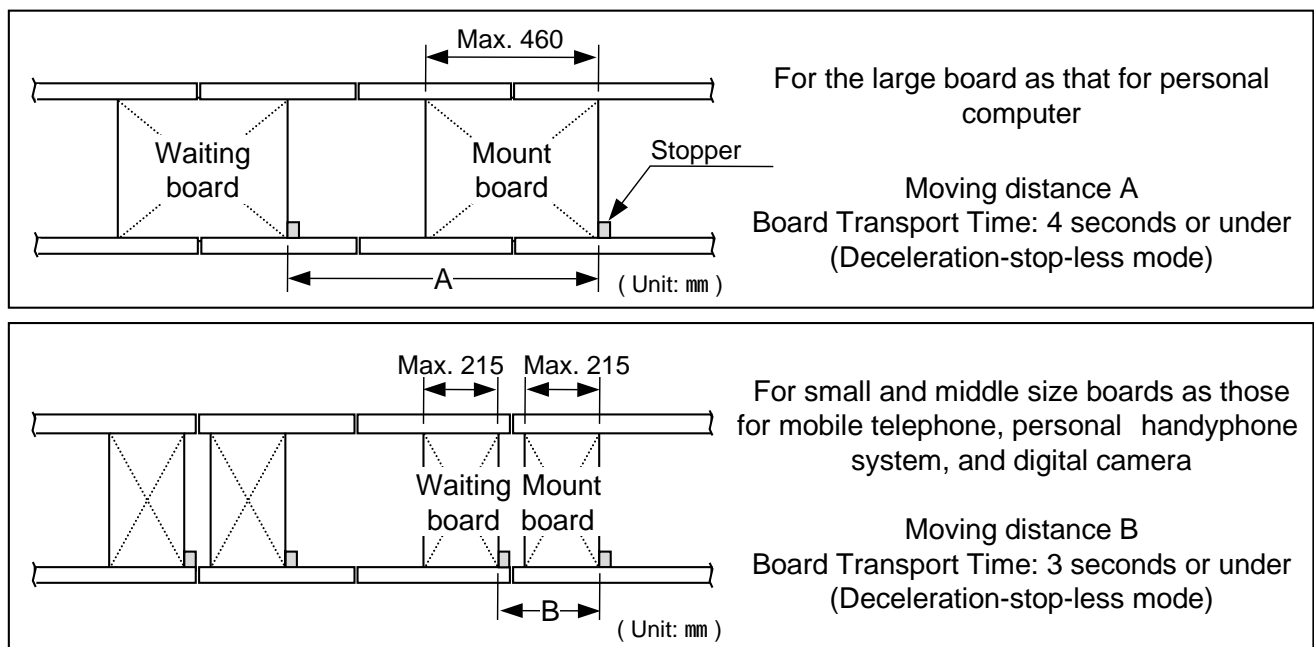

### Various feeder table modes

The feeder table on each stage is divided into two, and you can specify the mode per feeder table and carry out parts change according to the condition of production.

There are three types of modes.

- Joint mode
- Change mode
- Spare mode

\* If the tape chute (option) is selected, exchange mode and spare mode are not available.

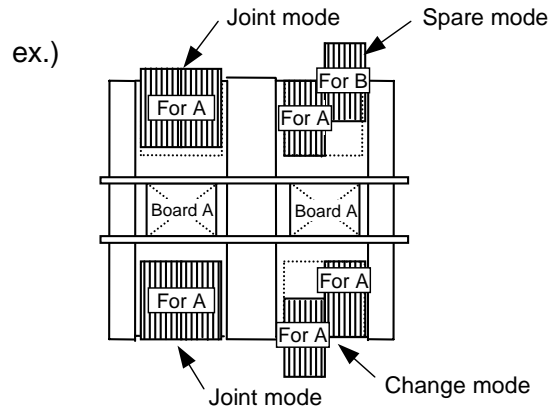

### High-accuracy mounting

#### Improved recognition resolving power

The line camera with wide view and high accuracy which is also used for the high accuracy multi-functional chip mounter CM120-MU greatly improved the recognition resolving power. You can carry out the stable mounting of such chips requiring the accuracy as 0603 (0201") chip. Besides, recognizing 6 chips together makes the high-speed mounting available.

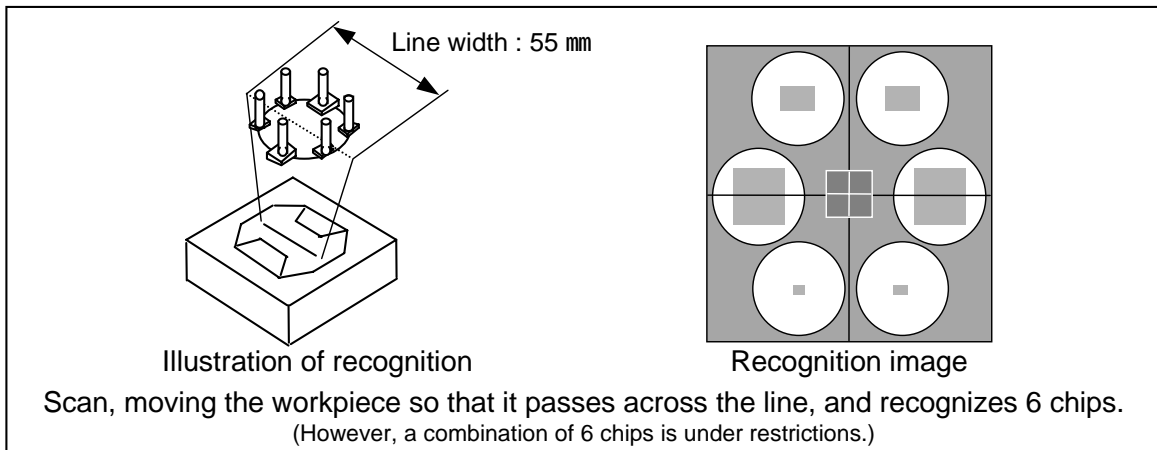

#### Optimum chip recognition

It automatically selects the optimum lighting type from the penetration and reflection, up to the chip shape. Using the reflection recognition achieved the high accuracy recognition of such chips which have the electrode on the rear side of the package as SOJ, PLCC, or CSP.

- \* To mount BGA and CSP, the optional side lighting is necessary. As for the chip recognition target, see page 12.
- \* Permeative/Reflective/Side mode in the same head/many chips batch recognition needs to be the same.

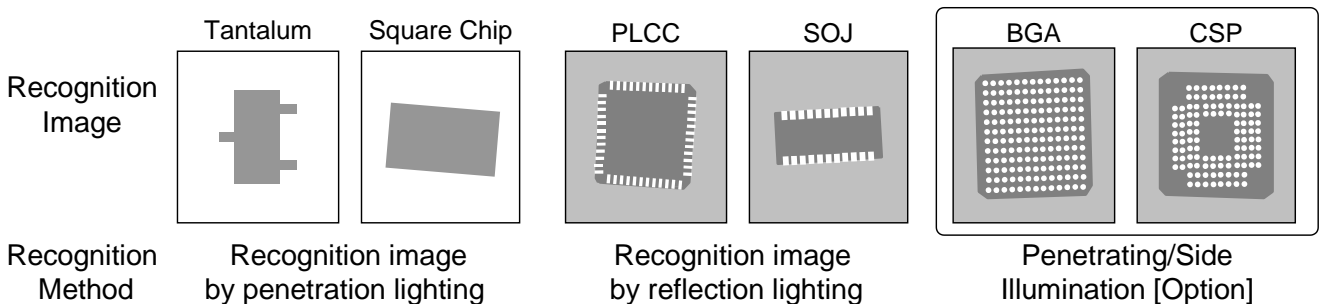

#### Calibration of mounting position

Usually, the camera position correction or the nozzle position correction which needs the skill is automatically carried out by the machine. This function can keep the mount accuracy high regularly.

## Pick-up Position Calibration

The head camera recognizes the pocket of the carrier tape and enables the manual teaching of the pick-up position. This improves the pick-up accuracy of minute chips like 0603 (0201").

\* However, the feeder slots No. 1 to No. 3 are not supported. 44-mm tape feeders are not supported.

## Automatic correction of X and Y faces

The automatic correction of X and Y faces can keep the mount accuracy high regularly.

## Improved operation rate and operatability

### Off-line data creation

All the data are created by data creating unit, PT100-G. You can create data on PT100-G even while machine is running. You can also create all the data of PT100-G support models unitedly. You can modify a part of data also by machine itself, and the modified data is fed back to PT100-G.

\* As for the hardware for PT100-G, prepare by yourself. Refer to the separate volume, "PT100-G Standard Specifications," for details of PT100-G.

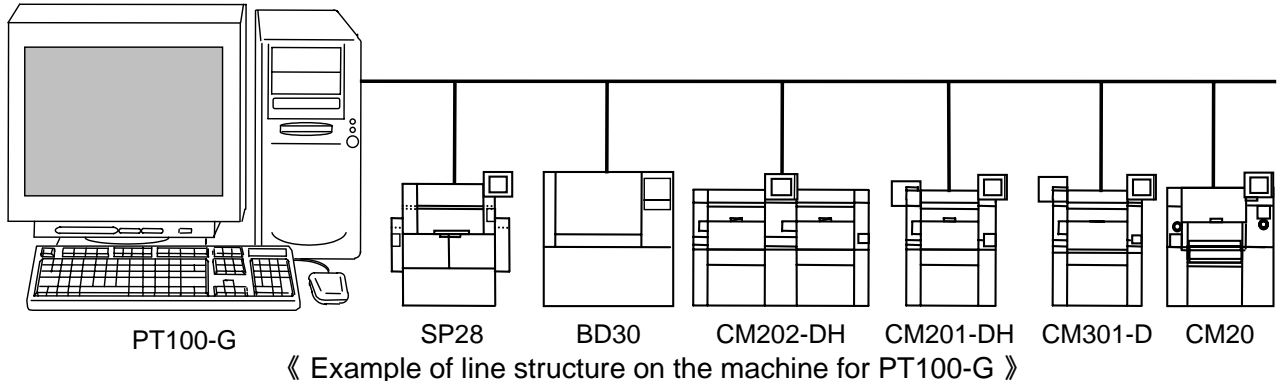

### Support pin batch change

The board support block which the board support pin is set in advance can be changed easily. The set-up of the support pin externally shortens the support pin change time to about 80 sec. per 4 positions during the machine change. (Usually it is 20 min. per 4 positions.)

\* The optional board support block and support tweezer are necessary for the set-up of the support pin on the outer side of the board.

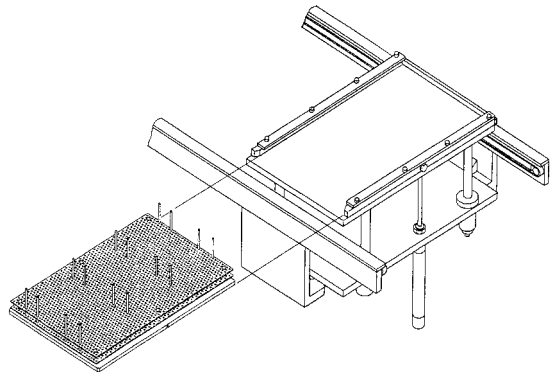

### LCD color touch panel

We adopt LCD color touch panel at operating unit, which realizes clear display and changeover between English and Japanese with one touch of a button.

#### Hierarchical operation

Operating screens are classified into three modes: Operator, Engineer and Serviceman to prevent improper operation to a minimum.

Moreover, screen configuration is simplified to a necessary minimum.

#### Tree jump function

At any screen, you can change over the screen to the main menu screen, which saves you a lot of time.

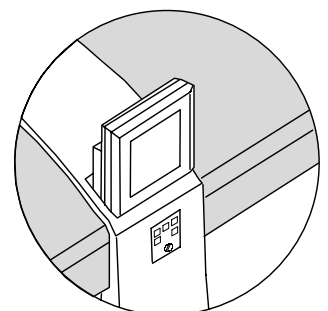

# 【 3 】 Specification

## 3 - 1 Equipment specification

Model: **CM201-DH/CM202-DH**

### Power supply

Rated voltage  
 3-phase, AC 200 V ± 10 V  
 3-phase, AC 220 V ± 11 V  
 Frequency 50 /60 Hz  
 Power  
 CM201-DH: 1.5 kVA  
 CM202-DH: 2.5 kVA

### Display area

LCD color touch panel (Interactive)  
 (Front side and rear side: Equipped)  
 · One-touch changeover between English and Japanese  
 · Recognition screen display  
 (Chip/board recognition screen is displayed in superimpose screen\*1 with one touch of a button.)  
 · Hierarchical operation (Operator/Engineer/Service man)  
 · Substantial help screen

\*1: Recognition screen is displayed on operating screen.

### Air supply

Air supply pressure Min. 490 kPa to Max. 780 kPa  
 Air supply quantity CM201-DH: 200 l/min (Normal) \*2  
 CM202-DH: 400 l/min (Normal) \*2

\* 8 l/min per a bulk feeder is necessary for using the bulk feeder [option].

\*2: Normal: (ISO/DIS 5598)

Temperature 20  
 Absolute pressure 101.3 kPa  
 Relative humidity 65 %

### Operating area

LCD color touch panel  
 Operating panel  
 Power supply switch

### Environmental conditions

Temperature 10 to 35  
 Humidity 25 % to 60 %  
 (Keep out condensation.)

### CM201-DH

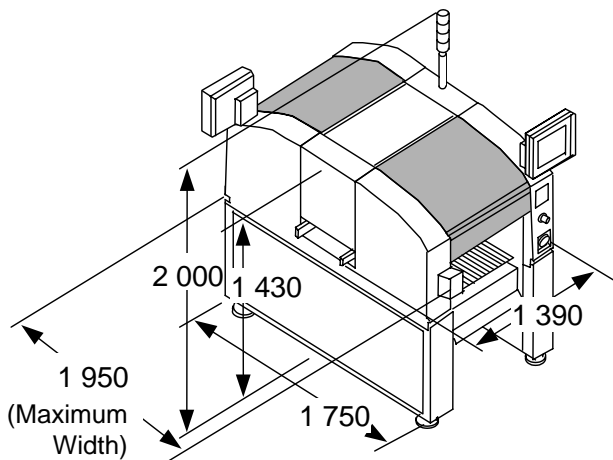

### CM202-DH

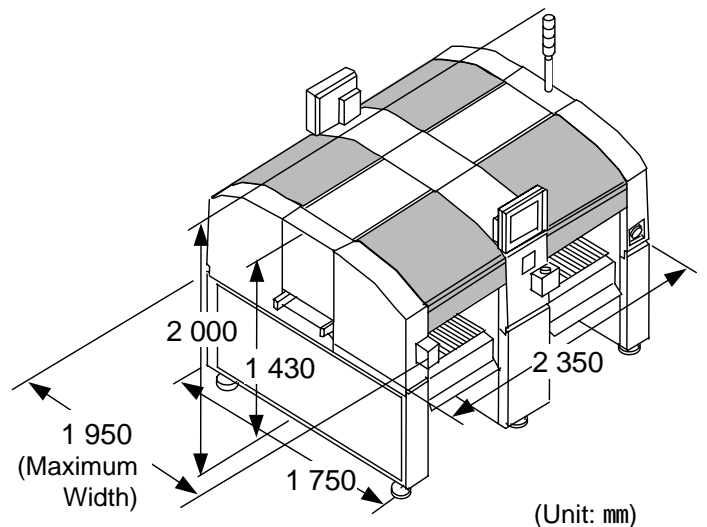

(Unit: mm)

### Mass

Main body (Standard structure)  
 CM201-DH: 1 600 kg  
 CM202-DH: 2 800 kg

### Coating color

Our standard color  
 White : TN-90 [Nittokoh No.]

\* The installation dimensions of the CM201-DH/CM202-DH are different from those of the CM201-D/CM202-D. So be careful when changing the D type to the DH type.



**Model: CM201-DHU/CM202-DHU**

**Power supply**

**Rated voltage**

- 3-phase, AC 380 V ± 19 V
- 3-phase, AC 400 V ± 20 V
- 3-phase, AC 440 V ± 22 V
- 3-phase, AC 480 V ± 24 V

**Frequency** 50 /60 Hz

**Power**

- CM201-DHU: 1.5 kVA
- CM202-DHU: 2.5 kVA

**Display area**

- LCD color touch panel (Interactive)  
(Front side and rear side: Equipped)
- One-touch changeover between English and Japanese
- Recognition screen display  
(Chip/board recognition screen is displayed in superimpose screen\*1 with one touch of a button.)
- Hierarchical operation (Operator/Engineer/Service man)
- Substantial help screen

\*1: Recognition screen is displayed on operating screen.

**Air supply**

**Air supply pressure** Min. 490 kPa to Max. 780 kPa

**Air supply quantity** CM201-DHU: 200 l/min (Normal) \*2  
CM202-DHU: 400 l/min (Normal) \*2

\* 8 l/min per a bulk feeder is necessary for using the bulk feeder [option].

\*2: Normal: (ISO/DIS 5598)

- Temperature 20
- Absolute pressure 101.3 kPa
- Relative humidity 65 %

**Operating area**

- LCD color touch panel
- Operating panel
- Power supply switch

**Environmental conditions**

- Temperature 10 to 35
- Humidity 25 % to 60 %  
(Keep out condensation.)

**CM201-DHU**

**CM202-DHU**

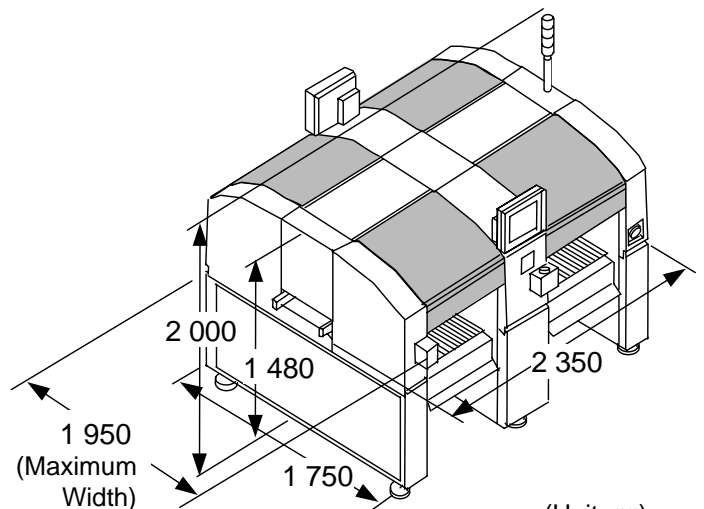
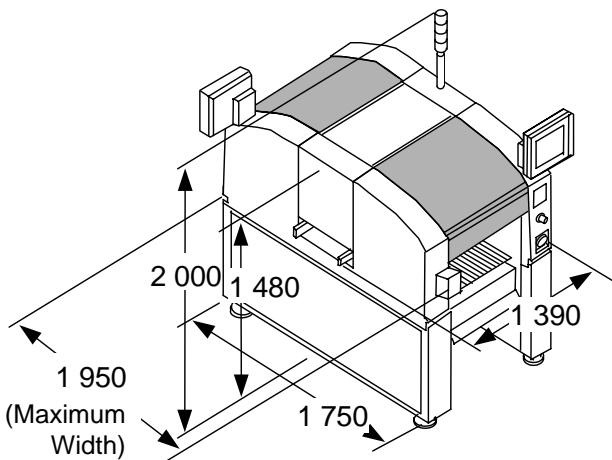

(Unit: mm)

**Coating color**

Our standard color  
White : TN-90 [Nittokoh No.]

\* The installation dimensions of the CM201-DHU/CM202-DHU are different from those of the CM201-DU/CM202-DU. So be careful when changing the DU type to the DHU type.

### 3 - 2 Product performance

Item	Specification		
Mounting tact time	CM201-DH: 0.18 s /chip ( under optimum condition )    1		
	CM202-DH: 0.09 s /chip ( under optimum condition )    1		
Mounting precision  * 2	Type of chip	Accuracy of position	Remarks
	Square chip	$\pm 0.1$ mm	0.113 s/chip (CM202), 0.226 s/chip (CM201) No pickup at the same time, Low speed recognition, Standard mode, under optimum condition
	0603 (0201") chip	$\pm 0.1$ mm	
		$\pm 0.05$ mm	0.130 s/chip (CM202), 0.260 s/chip (CM201) No pickup at the same time, Low speed recognition, High accuracy mode, under optimum condition
Mounting chip	0603 (0201") square chip to 24 mm × 24 mm		

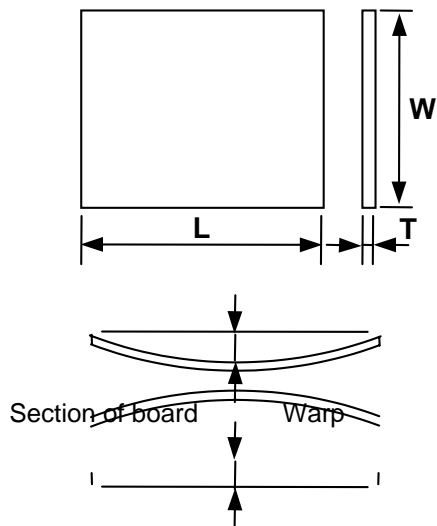
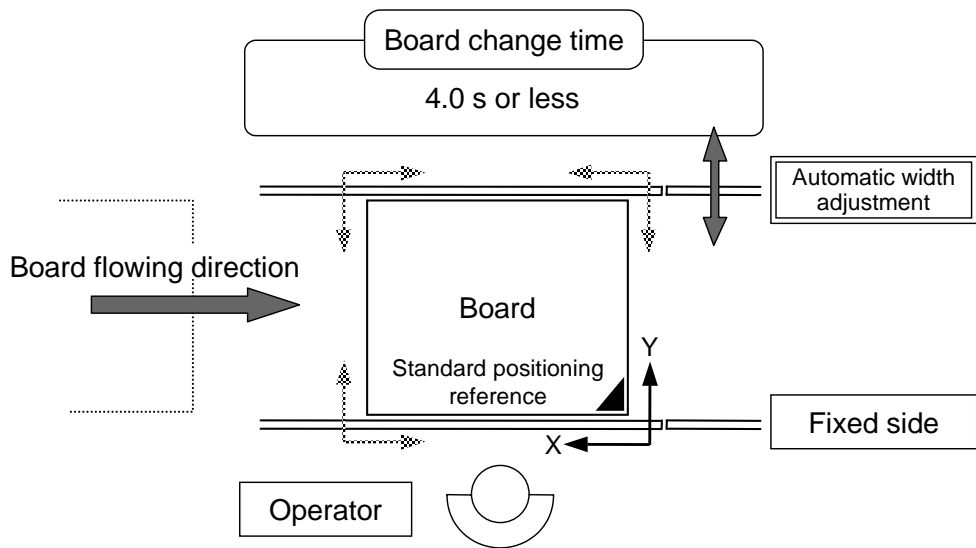

- Size of board (L × W)**  
 Min. 50 mm × 50 mm to Max. 460 mm × 360 mm
- Thickness of board (T)**  
 Standard Min. 0.5 mm to Max. 3.0 mm  
 [Special specification] Min. 1.0 mm to Max. 4.0 mm
- Tolerant range of warp**  
 Max. 1.0 mm

#### Remarks

- \* 1: "Optimum condition" : It means the pickup of 2 chips at the same time and mounting near the center of the largest board by 6 mm pitch of the head movement with high-speed recognition.
  - \* 2: These values are measured when board recognition, the glass board for evaluation and the dummy jig workpiece.
- Board flowing direction and reference position can be changed as options.  
 For information about the ceramic board, please inquire at our company.

## 【 4 】 Functions and structure

### 4 - 1 Feeder table mode

We have prepared following three production modes to give flexible responses to various production style of user. \* 1

#### Joint mode

This is the mode without dividing the feeder table. Chips during the operation cannot be fed, but the high-volume and high-mix parts can be set.

CM201-DH/DHU

Single tape feeder: **52** reels Double tape feeder: **104** reels

CM202-DH/DHU

Single tape feeder: **104** reels Double tape feeder: **208** reels

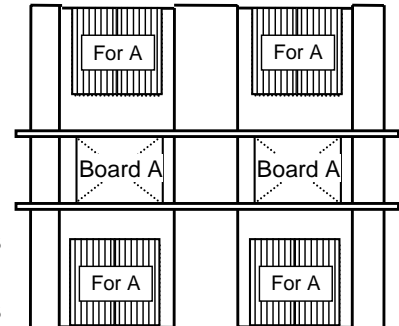

#### Change mode \* 2

Set the same parts to both of divided feeder tables. When parts on one side is used up, those on the other side are supplied. To pull out the feeder table which runs out of parts, push button. In this mode, the proper supply of parts during the out of parts makes it possible to minimise production down time.

Waiting feeder  
Operating feeder

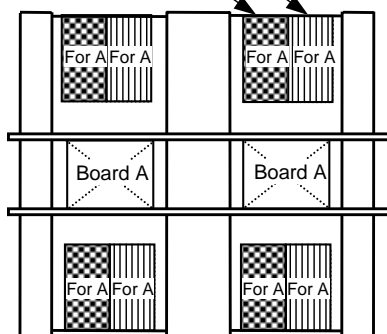

The operation is stopped, and this feeder is pulled out to the feeder change position.

This feeder starts the operation instead of the left.

Parts are used up

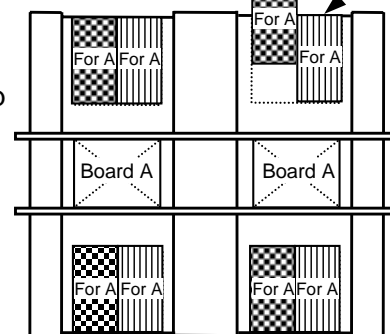

#### Spare mode

This is the mode for using only one of divided feeder table.

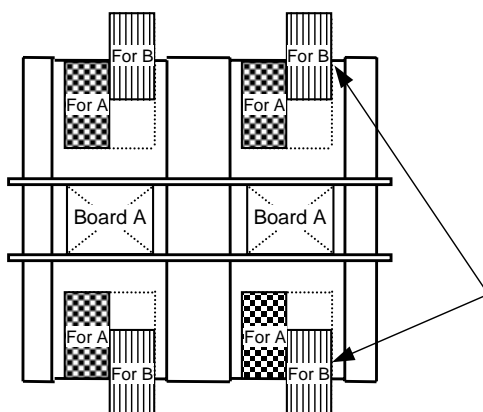

As the feeder table which is not used can be pulled out to the operator's side even during the production, you can set the tape feeder to be used for the next board.

The tape feeder for the board B can be set during the board A is produced.



#### Remarks

\* 1: The feeder slots No. 25 to 27 are under restrictions in the pick-up conditions, depending on the nozzle/feeder type.

\* 2: In exchange mode, the feeder slots No. 11 to 13 are under the same restrictions as "\* 1".

## 4 - 2 Nozzle

Various nozzle layouts by using the multi-row (6 nozzles) can respond to various production styles.

### Specifications of nozzle

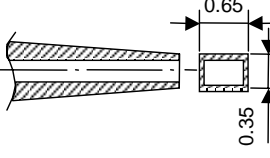
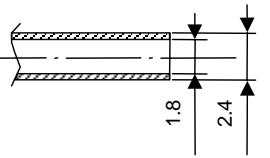
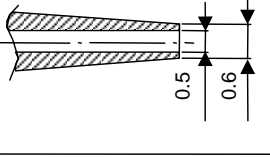
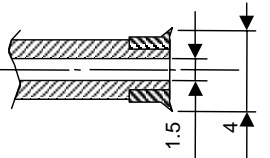
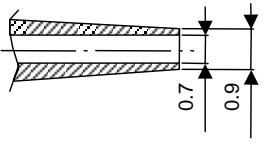
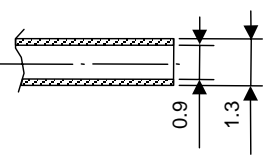
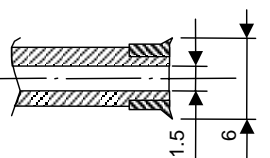
Names	No.	Shape (Unit: mm)	Objective chips (examples)	Names	No.	Shape (Unit: mm)	Objective chips (examples)
0603	205		0603 R, C (0201" R, C)	2.4	130		3225 R, C (1210" R, C) 4532 R, C (1812" R, C)
1005	110		1005 R, C (0402" R, C) 1608 R, C * 1 (0603" R, C)	4 pad	140		TAN-D Aluminum electrolysis-D SOP SOJ PLCC
1608	115		1608 R, C * 1 (0603" R, C) 2012 R, C * 2 (0805" R, C) S-Mini Tr, Di				
2125	120		2012 R, C * 2 (0805" R, C) 3216 R, C (1206" R, C)	6 pad (large)	450		SOP QFP PLCC to 24 mm x 24 mm

### Nozzle layout

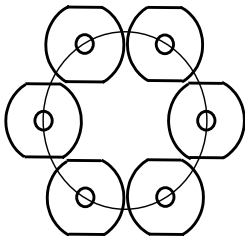

• 6 small nozzle

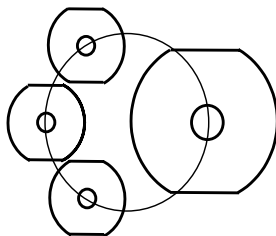

• 3 small nozzles  
a large nozzle

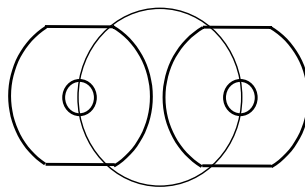

• 2 large nozzles

Example of nozzle layout  
CM202-DH/DHU (Image)

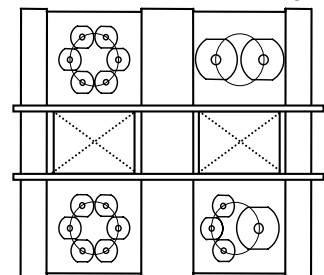

Small nozzle: ~ 12 mm x 12 mm, Large nozzle: 12 mm x 12 mm to 24 mm x 24 mm

### Nozzle check function

When the machine has six standard nozzles (No. 110, 115, 120, 130, 140, 450) built-in, the automatic check function is added in order to prevent incorrect nozzle setting.

### Remarks

All nozzles are options as well as the tape feeder so that you can select the best combination of them to make full use of CM201/202-DH/DHU, according to the production style of user.

If 44-mm tape feeder is used, only large nozzles are available for pick-up. And the pick-up position calibration by the head camera is not available.

When 0603 (0201") nozzles and special nozzles other than the above are used, it is possible that the nozzle check function will not work.

\* 1: For 1608 (0603") R and 1608 (0603") C, depending on the component shape, there is a possibility that a pick-up error, -deviation, and the like may arise. In that case, use 115-nozzles.

\* 2: [2012] is also called [2125].

【 5 】 Objective workpiece

5 - 1 Chip feeding type

Types of feeders

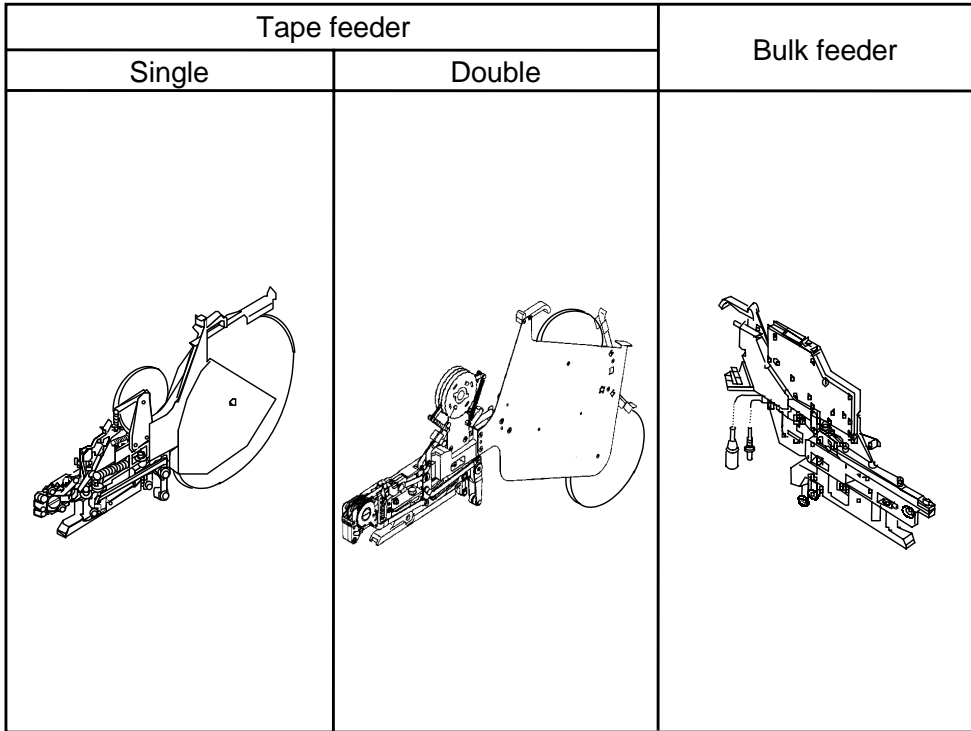

Number of setting reel

Types of feeder	Width of tape	Types	Diameter of reel	Setting pitch	Maximum setting reel		Remarks
					CM201	CM202	
Tape (M9 Type)	8 mm	Paper/ emboss	Small	21 mm	52	104	Single tape feeder
			Large	21 mm	104	208	Double tape feeder
	12 mm	Emboss	Small	21 mm	52	104	
			Large	42 mm	24	48	
	16 mm	Emboss	Large	42 mm	24	48	
	24 mm	Emboss	Large	42 mm	24	48	
	32 mm	Emboss	Large	63 mm	16	32	
	44 mm	Emboss	Large	63 mm	16	32	
32 mm	Adhesive	Large	63 mm	16	32		
Bulk feeder				21 mm	52	104	

\* Diameter of reel Small reel: 178 mm, Large reel: 178 mm to 382 mm

## 5 - 2 Recognition condition

### Arrangement of recognition units

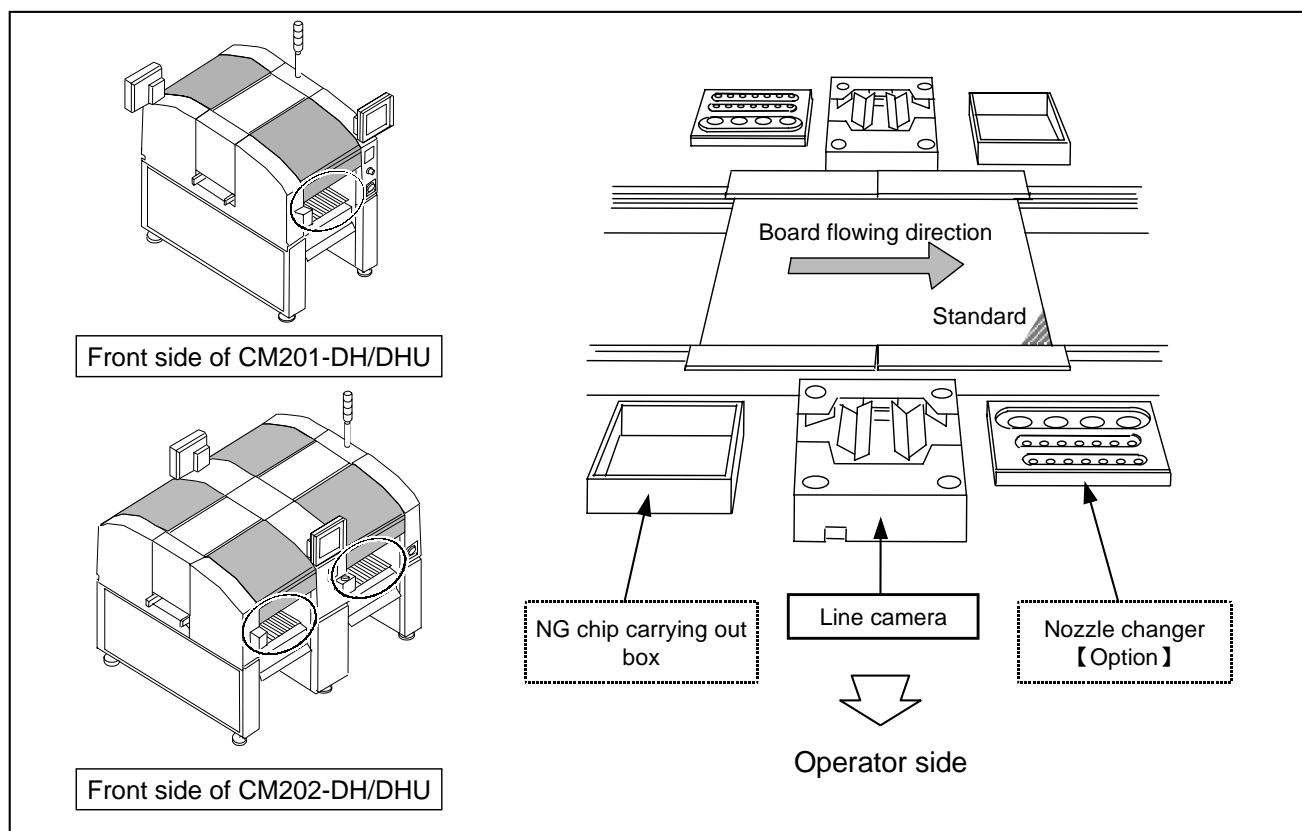

### Line camera

The position in picking up the chip and the angle deviation are corrected with the image of line camera. Whether there is the solder ball of BGA/CSP or not also can be inspected by the reflection recognition.

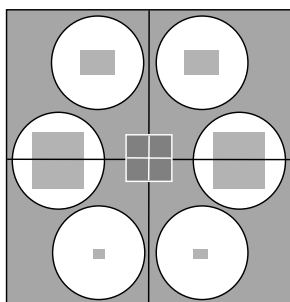

Recognition method	Recognition speed	Objective workpiece	Thickness of workpiece
Batch recognition	Low	Chip with the 0.5 mm lead and the 0603 (0201") chip.	Max. 6.5 mm
	Middle	Chip and BGA Chip with the lead of the pitch between 0.5 mm and 0.8 mm.	
	High	Square chip of 2012 (0805") or larger	

## Recognition condition for each objective chip

### Recognition condition of BGA [option]

The mountable condition of BGA is as follows.

(As a rule, BGA mounting is examined and experimented after getting the sample of it, and judged to be mounted or not.)

1. Outer size: 7 mm × 7 mm to 24 mm × 24 mm  
Thickness: 1.0 mm to 6.0 mm  
Pitch of bump: 1.0 mm to 1.5 mm  
Diameter of bump: 0.5 mm, 0.7 mm, 0.9 mm  
Arrangement of bump: The pitch of bump matches the size. The missing bump or zigzag pattern matches the rule related to BGA by JEDEC and EIAJ.
2. The simultaneous recognition of appearance and solder ball of BGA is for the one whose body is made of the glass epoxy. The recognition depends on the condition of the mounting surface of solder ball (pattern, with through hall or without it, or luster, etc.).
3. BGA which is made of ceramic and has the gold body is mounted with only the contour recognition.
4. Supply style  
Supplying with the tape. However, the bottom face of it must have the ball shape terminal.

### CSP Recognition condition [option]

The followings are the mountable conditions of CSP.

(Basically, mounting CSP is determined and experimented after getting the sample of it, and then it is judged to be mounted or not.)

1. Outer size: 7 mm × 7 mm to 20 mm × 20 mm  
Thickness: 1.0 mm to 3.5 mm  
Pitch of bump: 0.5 mm to 1.0 mm  
Diameter of bump: 0.3 mm to 0.7 mm  
Shape of bump: Sphere or lead shape  
Material of bump: High-temperature solder, eutectic solder, 42 alloy lead  
Number of bump: to 625 (Line × row : Matrix of Min. 3 × 3 to Max. 25 × 25 )  
Arrangement of bump: The pitch of bump matches the size. The missing bump or zigzag pattern matches the rule related to CSP by JEDEC and EIAJ.
2. The simultaneous recognition of appearance and solder ball of CSP is for the one whose body is made of the glass epoxy. The recognition depends on the condition of the Mounting surface of solder ball (pattern, with through-hall or without it, or luster, etc.)
3. CSP which is made of ceramic and has the gold body is mounted with only the contour recognition.
4. Surface of ball  
The surface of ball should be free from the blur due to oxidation.  
(It needs to be checked whether to recognize or not, according to the condition of oxidation.)
5. Supply style  
Supplying with the tape. However, the bottom face of it must have the ball shape terminal.

## Recognition condition of QFP [option]

The mountable condition of QFP is as follows.  
(As a rule, QFP mounting is examined and experimented after getting the sample of it, and judged to be mounted or not.)

Chip size	Lead pitch
12 mm × 12 mm and below	0.5 mm
12 mm × 12 mm and over ~ 24 mm × 24 mm and below	0.8 mm



### 5 - 3 Range of mount

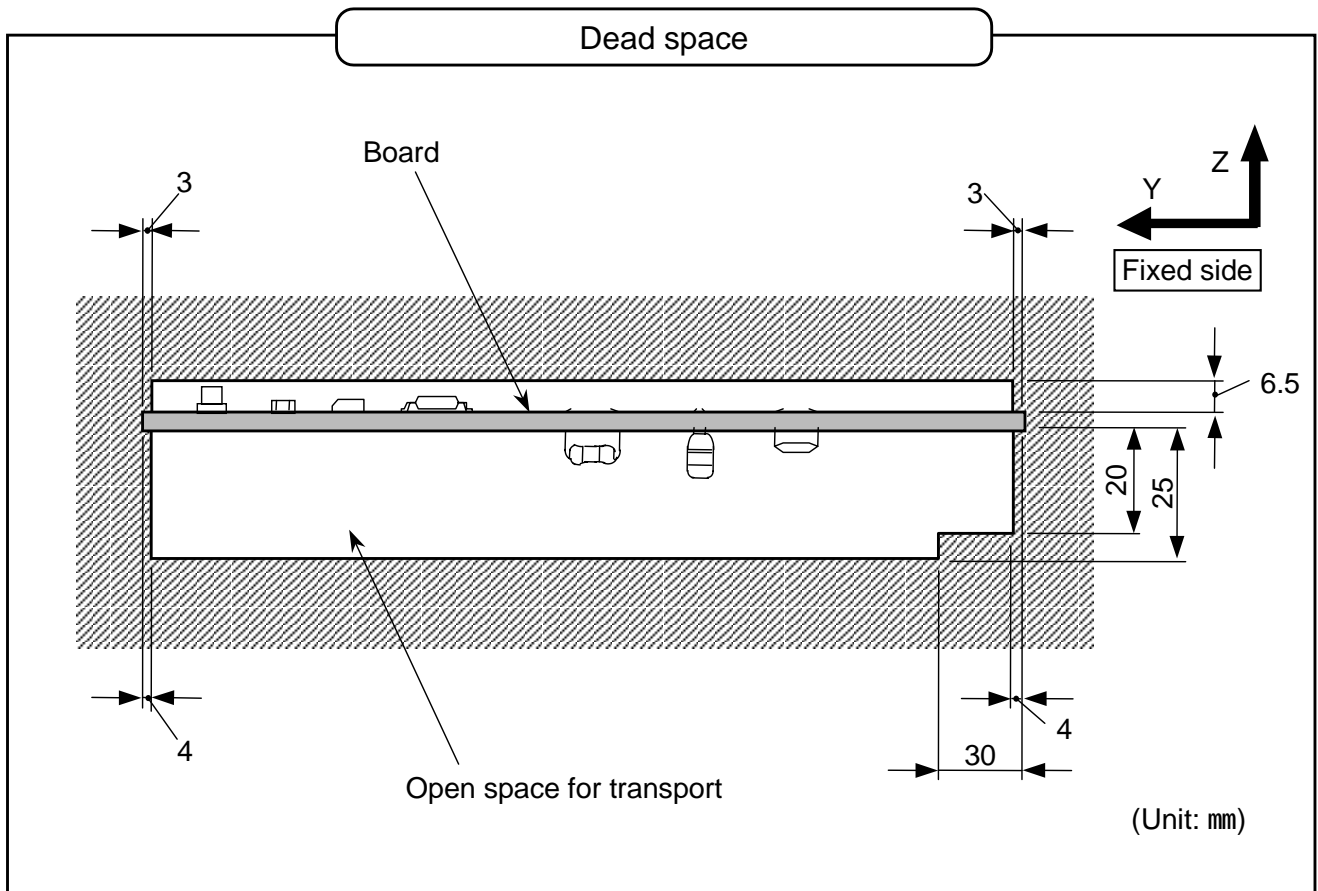

### Board Notch Conditions

To secure the board stop position by the board stopper and secure the stable operation of the board detection sensor, the following conditions are set on the position and the size of the board notch.

[The below figure indicates the case of the left-to-right flow/front reference (standard). The other conditions (options) follow this, too.]

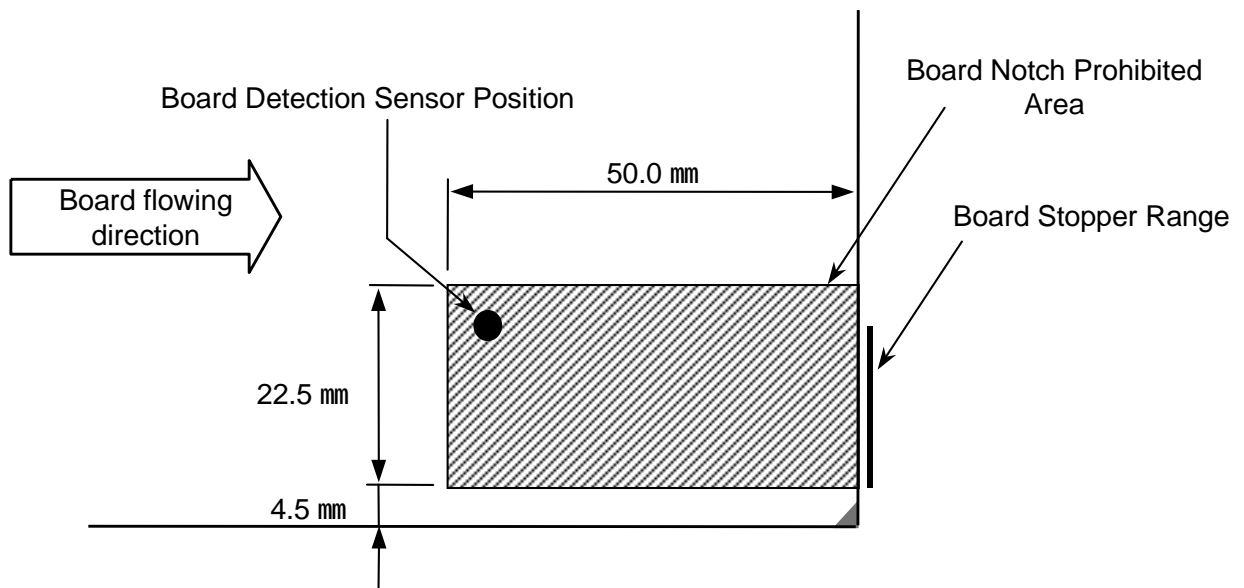

## 【 6 】 Program data structure

### 6 - 1 Data structure

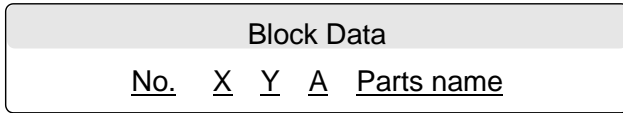
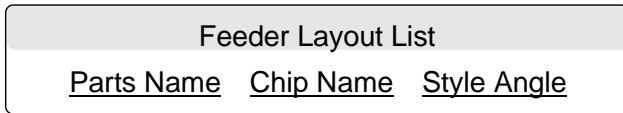
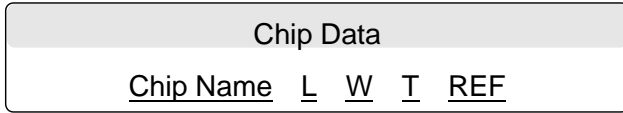

Max. 10 000 points

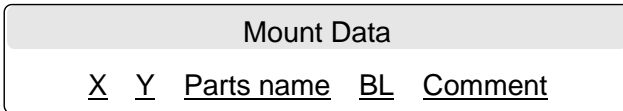
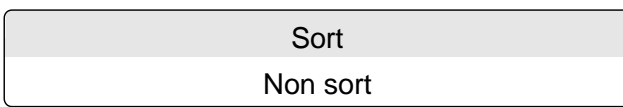
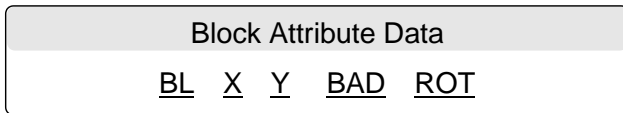

Max. 10 000 points

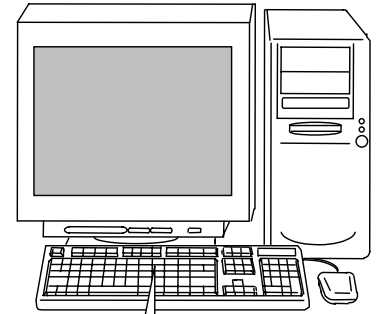
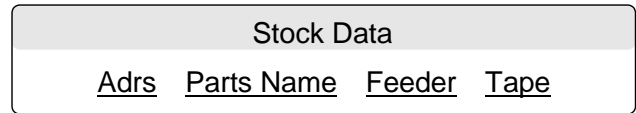
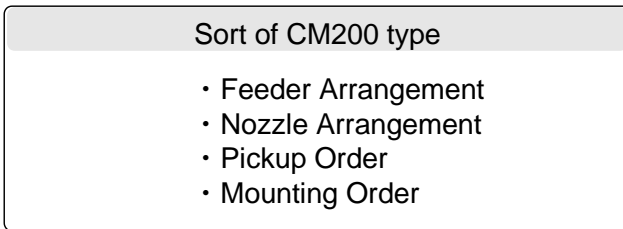

Data creating unit PT100-G

### Remarks

All upper data are created on the data creating unit PT100-G.  
However, some data can be corrected on the machine.

The data corrected on the machine and those after teaching are automatically fed back to PT100-G.

The origin of the coordinate data can be set at every four angles.

As for the hardware for PT100-G, prepare for yourself. Refer to a separate volume, "PT100- G Standard Specifications, " for details of PT100-G.

## 【 7 】 Basic configuration

### 7 - 1 Standard machine configuration

#### CM201/CM202

##### Main body

#### CM201

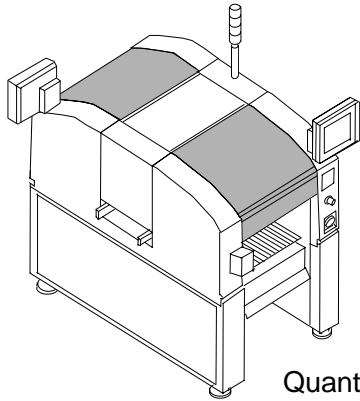

Quantity: 1

#### CM202

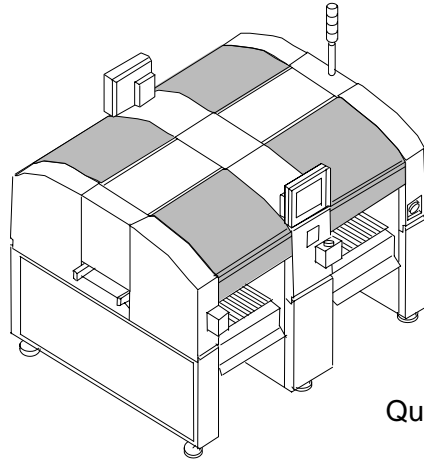

Quantity: 1

##### Accessories

Items	Quantity	
	CM201	CM202
Standard support pin	40	80
Axis fixing metal fitting (for machine transfer)	1	
Eyebolt (for machine transfer)	4	
Grease for the head (with grease)	1	
Nozzle Filter Set / Remove Jig	1	
Cutting Maintenance Jig	1	
Instruction manual <ul style="list-style-type: none"> <li>• Operating Manual</li> <li>• Programming Manual</li> <li>• Maintenance Manual</li> <li>• Parts List</li> </ul>	1	
<ul style="list-style-type: none"> <li>• Above CD-ROM</li> </ul>	1	
System disk <ul style="list-style-type: none"> <li>• Machine system ( CD - R )</li> <li>• Key disk</li> <li>• Recognition device system disk</li> <li>• Machine parameter disk</li> </ul>	1 set	

##### Data creation

We ask you for preparing the hardware for PT100-G.  
 Refer to a separate volume, "PT100-G Standard Specifications" for details.



PT100-G

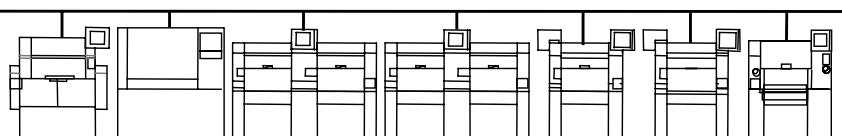

SP28 BD30 CM202-DH CM202-DH CM201-DH CM301-D CM20

## 7 - 2 Options

Options are classified as follows.

Mark	Description
<b>Factory</b>	These options need to be supported when the machine is being manufactured before shipment.
<b>On-site</b>	These options can be added after the machine has been delivered. However, a construction work is required on the spot.
<b>Customer</b>	These options can be added after the machine has been delivered. A construction work on the spot is not required.

\* Depending on user's machine specification, the manufacturing No., etc., some options may not fit the above classification. For details, please consult us before purchasing the machine.

Following classification is given to CM201/CM202 depending on its application.

Mark	Description
Each beam	Each beam can be applied separately.
Whole machine	Not each head but as a machine, it is applied.

\* "Beam" is a material to install the head.  
There are 2 for CM201, and 4 beams for CM202.

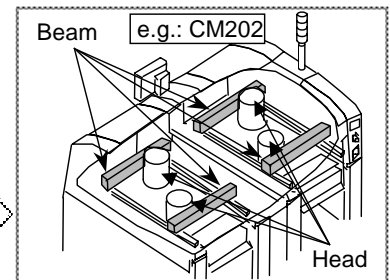

Please select options which answer your purposes.

No.	Purpose / Function	Option name	Mark	
<b>A</b>	1 To change the board carrying reference/flowing direction	• Reference/flow direction change support	<b>Factory</b>	Whole machine
	2 To set the transfer line height 950 mm above the floor	• For transfer line 950 mm	<b>Factory</b>	_____
	3 To mount by the board end reference	• Board Side Clamp	<b>Factory</b>	Whole machine
	4 To install the temporary extension conveyor to the inlet or outlet of board transfer conveyor of machine	• Temporary extension conveyor	<b>On-site</b>	_____
	5 To adjust the board transport speed	• Board Conveyor Transport Speed Adjustable Support	<b>Factory</b>	_____
<b>B</b>	1 To set up the position change of board support pin externally, to shorten the time for machine change	• Board support block	<b>Customer</b>	_____
	2 To set up positioning the support pin for new board externally, to shorten the time for machine change	• Support pin setting jig	<b>Customer</b>	_____
	3 To change nozzle automatically in machine change	• Nozzle changer	<b>Factory</b>	Whole machine
<b>C</b>	1 To select the nozzle for each production style	• Nozzle	<b>Customer</b>	_____
	2 This needs for storing nozzles out of machine.	• Nozzle case	<b>Customer</b>	_____
	3 To select the tape feeder for each production style	• Tape feeder	<b>Customer</b>	_____
	4 To use the double tape feeder	• Double tape feeder • Unit for double tape feeder	<b>Customer</b> <b>Factory</b>	_____ Whole machine
	5 To use the bulk feeder	• Bulk feeder • Unit for bulk feeder • Bulk feeder maintenance kit	<b>Customer</b> <b>Factory</b> <b>Customer</b>	_____ Whole machine
	6 To manage and store the unused tape feeder or that of other production machine neatly.	• Feeder stand	<b>Customer</b>	_____
<b>D</b>	1 To mount BGA, CSP	• Side lighting and side lighting amplifier	<b>Factory</b>	Each beam
<b>E</b>	1 This needs for the regular maintenance.	• Lubrication set	<b>Customer</b>	_____
	2 This needs for the correction of machine.	• Adjustment jig • Plane surface calibration jig	<b>Customer</b> <b>Customer</b>	_____
	3 To improve the operatability of chip feeding	• Tape feeder setting jig (Fixing type) • Tape feeder setting jig (Adjusting type)	<b>Customer</b> <b>Customer</b>	_____

\* For information about the ceramic board, please inquire at our company.

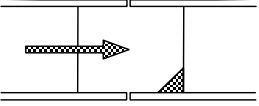
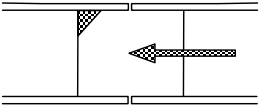
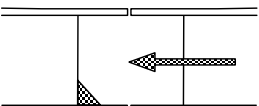
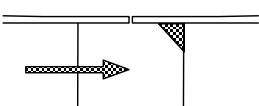
<b>A-1</b>	To change the board carrying reference/flowing direction			
Option name			Remarks	
<b>Factory</b> <input type="checkbox"/> Whole machine  Reference/Flow direction change support	Front reference/Left	Right		[Standard] Board stopper Type A
	Rear reference/Right	Left		Board stopper Type A
	Front reference/Right	Left		Board stopper Type B
	Rear reference/Left	Right		Board stopper Type B
* The stopper module for each reference/flow direction is necessary.				

<b>A-2</b>	To set the height of board transfer line 950 mm above the floor		
Option name			
<b>Factory</b> <input type="checkbox"/>	For the transfer line 950 mm		
* The standard height of board transfer line is 900 mm above the floor.			

<b>A-3</b>	To mount by the board end reference		
Option name			
<b>Factory</b> <input type="checkbox"/>	<input type="checkbox"/> Whole machine	Board Side Clamp	
* This is required when mounting by the board end reference.			

**A-4** To install temporary extension conveyor to the inlet or outlet of board transfer conveyor of machine

Option name

**On-site**

Temporary extension conveyor

The length of temporary extension conveyor is 500 mm.

Make use of this for examining the mount board between stations or keeping the space for maintenance.

It can be installed to either side of inlet or outlet for an additional module. Specify either side to install it.

Add two modules for installing to both of inlet and outlet.

**A-5** To adjust the board transport speed

Option name

**Factory**

Board Conveyor Transport Speed Adjustable Support

The speed at the board transport can be reduced. (The speed cannot be faster than the standard speed.)

The collision speed at the stopper positioning is adjustable. (The low collision positioning control is also performed even in standard.)

In order to set the speed controller, the simple extension conveyor is required to be set at the inlet and outlet sides on the machine.

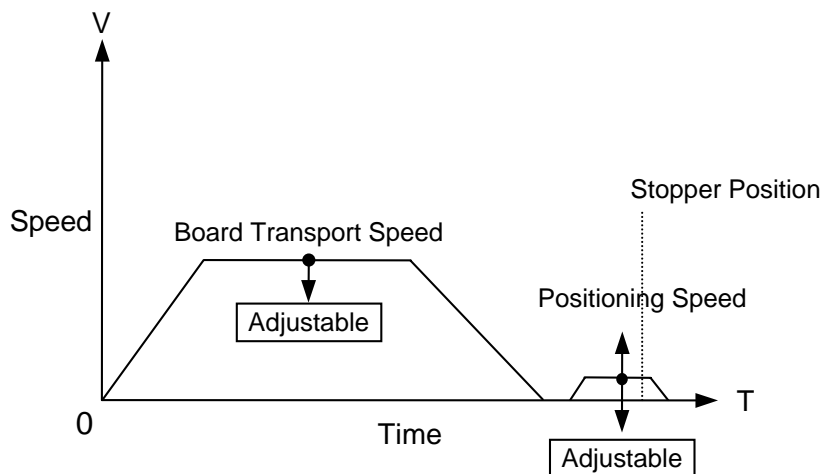

**B-1**

To set up the position change of board support pin externally, to shorten the time of changing machine

## Option name

**Customer**

Board support block

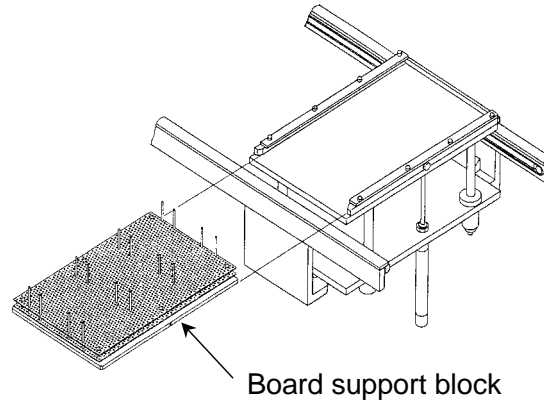

Board support block

The board support block for mount by setting to the machine, is attached as the standard.  
Purchase another one if it is necessary for setting up externally.

- \* To decide the support pin position of new board externally, purchase "support pin setting jig" [option] separately.
- \* This option can be shared with the CM301-D, however cannot be shared with the CM202-D.

**B-2**

To decide the support pin position of new board externally, to shorten the time of changing the machine

## Option name

**Customer**

Support pin setting jig

To set up the support pin externally, purchase the "board support block" [option] separately.

- \* This option can be shared with the CM301-D, however cannot be shared with the CM202-D.

**B-3**

To change the nozzle automatically in changing machine

## Option name

**Factory** Whole machine

Nozzle changer

This is used for changing nozzle to change the nozzle layout to the optimum one in changing machine.

- \* It is not for such a nozzle change during mounting a board as the nozzle changer on a multi-functional mouter.  
Causes
  - Changing nozzles during mounting a board makes the mount tact time down.
  - As 24 nozzles can be set on this machine, the multi-functional machine method is not adopted.
- \* Using the nozzle change function may shorten the life of the nozzle and the nozzle holder. (When the change is performed 10 times per day, the life will be about 3 years.)
- \* This may not be able to be used depending on the combination with the other special specification.  
(Combination with the ceramic board support special specification)

**C-1**

To select the nozzle for each production style

Option name	All nozzles are options as well as the tape feeder, so that users can select the optimum combination of nozzles to make full use of quality of CM201/CM202.
<b>Customer</b> Nozzle	

List of nozzle

Nozzle No.	205	110	115	120	130	140	450
Nozzle name	0603	1005	1608	2125	2.4	4 pad	6 pad (large)
Objective chip (example)	0603 R, C (0201" R, C)	1005 R, C (0402" R, C) 1608 R, C*1 (0603" R, C)	1608 R, C*1 (0603" R, C) 2012 R, C*2 (0805" R, C) S-Mini Tr, Di	2012 R, C*2 (0805" R, C) 3216 R, C (1206" R, C)	3225 R, C (1210" R, C) 4532 R, C (1812" R, C)	TAN-D Aluminum electrolysis-D SOP SOJ PLCC	SOP QFP PLCC

Classification diagram of production style

We classified the production style of user into following six types and simulated the necessary number of nozzles.

Types	Names	Information
1.	1005 mass production	Mobile telephone and ultra small split board
2.	1608 mass production	Personal computer or automotive
3.	2012 mass production *2	General electrical devices
4.	( 1+2 ) type	Mixture of type 1 and 2
5.	( 2+3 ) type	Mixture of type 2 and 3
6.	Complete application	Non-restricted

\*1: For 1608 (0603") R and 1608 (0603") C, depending on the component shape, there is a possibility that a pick-up error, -deviation, and the like may arise. In that case, use 1151-nozzles.

\*2: [2012] is also called [2125].

The diagram of nozzle number for each production style and recommendation pattern

Decide the number of nozzle referring to the following figure. Make contact with us for details.

Specification	Production style	205	110	115	120	130	140	450	Sum
		0603	1005	1608	2125	2.4	4 pad	6 pad (large)	
CM201-DH a set	1. 1005 mass production	-	12	6	4	2	2	2	28
	2. 1608 mass production	-	2	12	6	4	2	2	28
	3. 2012 mass production *2	-	2	4	12	6	2	2	28
	4. ( 1+2 ) type	-	12	12	6	4	2	2	38
	5. ( 2+3 ) type	-	2	12	12	6	2	2	36
	6. Complete application	-	12	12	12	12	12	4	64
CM202-DH a set	1. 1005 mass production	-	24	6	4	2	2	2	40
	2. 1608 mass production	-	2	24	6	4	2	2	40
	3. 2012 mass production *2	-	2	4	24	6	2	2	40
	4. ( 1+2 ) type	-	24	24	6	4	2	2	62
	5. ( 2+3 ) type	-	2	24	24	6	2	2	60
	6. Complete application	-	24	24	24	24	24	8	128
CM202-DH 2 sets	1. 1005 mass production	-	48	8	6	4	2	2	70
	2. 1608 mass production	-	4	48	8	4	2	2	68
	3. 2012 mass production *2	-	2	6	48	6	2	2	66
	4. ( 1+2 ) type	-	48	48	8	4	2	2	112
	5. ( 2+3 ) type	-	4	48	48	6	2	2	110
	6. Complete application	-	48	48	48	48	48	16	256
CM202-DH 4 sets	1. 1005 mass production	-	96	10	8	6	2	2	124
	2. 1608 mass production	-	6	96	8	6	2	2	120
	3. 2012 mass production *2	-	4	6	96	8	2	2	118
	4. ( 1+2 ) type	-	96	96	8	6	2	2	210
	5. ( 2+3 ) type	-	6	96	96	8	2	2	210
	6. Complete application	-	96	96	96	96	96	32	512

Special nozzle

The special nozzle must be the nozzle included in the parts targeted as the high-speed chip mounter.

It is different from the multi-functional chip mounter, so the support is under restrictions.

When the special nozzle is used or permeative recognition and reflective recognition are intermingled, the tact may be down. Make contact with us for details.



**C-2**

This needs for storing nozzles out of machine.

Option name

**Customer**

Nozzle case

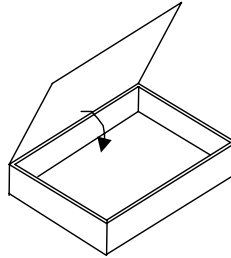

The small nozzle/66 and the large nozzle/6 can be contained.  
Decide the number of additional case yourself depending on the number of nozzles.

**C-3**

To select the tape feeder for each production style

Option name	Tape for use					
<b>Customer</b>	No.	Width (mm)	Types	Feeding pitch	Width of groove	Diameter of reel
	1	8	Paper/Emboss	1	Wide	Small (Double) *1
	2	8	Paper/Emboss	0.5	Standard	Small (Double) *1
	3	8	Paper	0.5	Standard	Small
	4	8	Paper	0.5	Standard	Large
	5	8	Paper	1	Standard	Small
	6	8	Paper	1	Standard	Large
	7	8	Emboss	0.5	Standard	Small
	8	8	Emboss	0.5	Standard	Large
	9	8	Emboss	1	Standard	Small
	10	8	Emboss	1	Standard	Large
	11	8	Emboss	1	Wide	Small
	12	8	Emboss	1	Wide	Large
	13	12	Emboss	1		Small
	14	12	Emboss	1		Large
	15	12	Emboss	2		Small
	16	12	Emboss	2		Large
	17	12	Emboss	3		Large
	18	16	Emboss	1		Large
	19	16	Emboss	2		Large
	20	16	Emboss	3		Large
	21	16	Emboss	4		Large
	22	24	Emboss	1		Large
	23	24	Emboss	2		Large
	24	24	Emboss	3		Large
	25	24	Emboss	4		Large
	26	24	Emboss	5		Large
	27	24	Emboss	6		Large
	28	32	Emboss	2		Large
	29	32	Emboss	3		Large
	30	32	Emboss	4		Large
	31	32	Emboss	5		Large
	32	32	Emboss	6		Large
	33	44	Emboss	2		Large
	34	44	Emboss	3		Large
	35	44	Emboss	4		Large
	36	44	Emboss	5		Large
	37	44	Emboss	6		Large
	38	44	Emboss	8		Large
	39	44	Emboss	9		Large
40	32	Adhesive	3	Large		

The tape feeders for CM201/CM202 can be used for CM20F-M and CM120-MU.  
(It does not include the double tape feeder)

The tape feeders for CM20F-M, CM120-MU can be also installed to CM201/CM202. However, use the upper new type of tape feeder, considering the life of it and reliability.

\*1 : It is the double tape feeder. It needs the unit for double tape feeder [option] on the main body.

\* : Please consult us if the emboss depth is 6 mm or over.

\* : For the tape feeders other than the standard ones above, the pick-up position teaching by means of the head camera is disabled.

C-4 To use the double tape feeder					
Option name	Tape to be used				
	Width (mm)	Types	Length (mm)	Reel	Groove
<b>Customer</b> Double tape feeder	8	Paper/Emboss	4	Small	Wide
	8	Paper/Emboss	2	Small	Standard
<b>Factory</b> Whole machine For double tape feeder	* With the cutting unit and the empty tape box.				
<p>Decide the number of additional double tape feeders by yourself.</p> <p>* It needs the own tape feeding system on the machine to be applicable for the double tape feeder.</p> <p>* Even the unit for double tape feeder is installed, the single tape feeder can be set as usual.</p>					

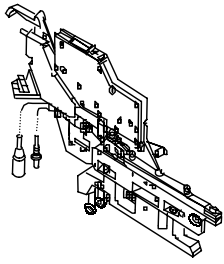
C-5 To use the bulk feeder	
Option name	Objective chip
<b>Customer</b> Bulk feeder 	1005C
	1005R
	1608C
	1608R
	2012C t0.6
	2012C t0.85
	2012C t1.25
	2012R
<b>Factory</b> Whole machine Unit for bulk feeder	—
<b>Customer</b> Bulk feeder maintenance kit	—
<p>Decide the number of additional bulk feeders by yourself.</p> <p>To use the bulk feeder, it is necessary to install the unit for bulk feeder to the machine side.</p> <p>* Even the unit for bulk feeder is installed, the single tape feeder can be set as usual.</p> <p>* Refer to the separate volume, "Standard specifications Bulk Feeder" for details of bulk feeder, the unit for bulk feeder, and the bulk feeder maintenance kit.</p>	

**C- 6** To manage and store unused tape feeder or that of another production style neatly

Option name

**Customer**

Feeder stand

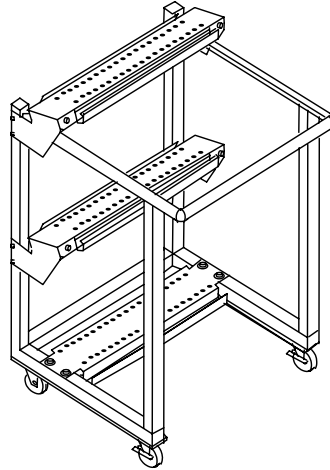

This is the stand for M9 type tape feeder. Make use of this for managing, storing, and setting up feeders externally.

\* Decide the number of additional feeders yourself, depending on the number of stock and using method.

**D-1** To mount BGA, CSP

Option name

**Factory** Each beam

Side lighting and side lighting amplifier

The lighting for ball recognition is necessary for mounting BGA and CSP.

A side lighting amplifier can control two of side lighting on a stage.

You do not have to install the lighting for all lighting in the machine. It can be set optionally for each beam.

• Recommended installation layout (CM202)

Setting position			
	Lightings	1	2
Amplifiers	1	1	2

\* Position name is changed ( AR AS ) ( BR BS )  
 ( AF AM ) ( BF BM )

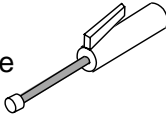
<b>E-1</b> This is necessary for the regular maintenance.				
Option Name	Usage	Description	Qty.	Remarks
<b>Customer</b> Lubrication set	Greasing the designated points on the machine	Grease gun /nozzle 	1	Common to the CM301
Use this for the regular application of grease as the machine maintenance. * It is necessary in purchasing the first standard machine.				

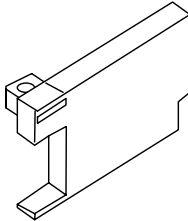
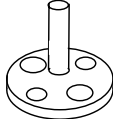
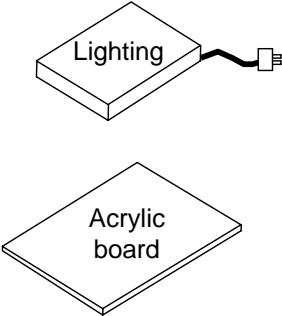
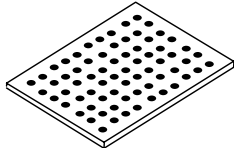
<b>E-2</b> This is necessary for the correction of machine.				
Option Name	Usage	Description	Qty.	Remarks
<b>Customer</b> Adjustment jig	For nozzle height teach	Nozzle height teach jig 	1	It is necessary purchasing the first standard machine.  CM201/202 exclusive jig  The mounting position teaching requires 110-nozzle × 12 and a 8 mm-by-0.5p tape feeder × 2.
	For line camera teach	Line camera teach jig 		
	For placement point teach	Placement Point calibration jig 		
<b>Customer</b> Plane surface calibration jig	Teaching of plane surface calibration	Glass board for plane Surface calibration 	1	Common to the <sup>*1</sup> CM201/202 and the CM301.  More high-accurate calibration is realized by enlarging the area of the plane calibration jig for the CM201/202.
This is a set of jigs for each adjustment. <sup>*1</sup> : As for the CM201-DH/DHU and CM202-DH/DHU, however, the system software of ver. 1.42 (055) or later is required.				

**E-3** To improve the operatability of supplying chips

Option name

**Customer**

Tape feeder setting jig  
(fixing type)

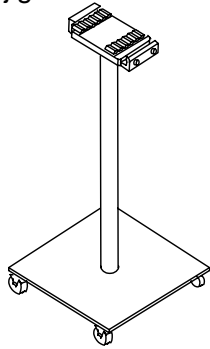

**Customer**

Tape feeder setting jig  
(adjusting type)

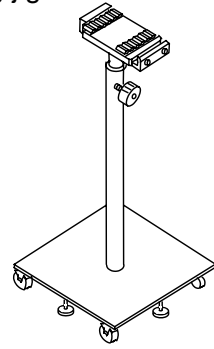

These are the setting jig for M9 type tape feeder. There are two of fixing type and adjusting type.  
We recommend to use a tape feeder setting jig per a machine.

\* Decide the number of additional feeders yourself, depending on the number of stock and using method.

# 【 8 】 Others

## 8 - 1 Safety devices

We install the following safety devices to CM201/CM202 for the safety use of the machine. When the emergency switch is pressed during machine operation or the cover is opened, they stop the operation forcibly.

CM201

CM202

View from above

View from above

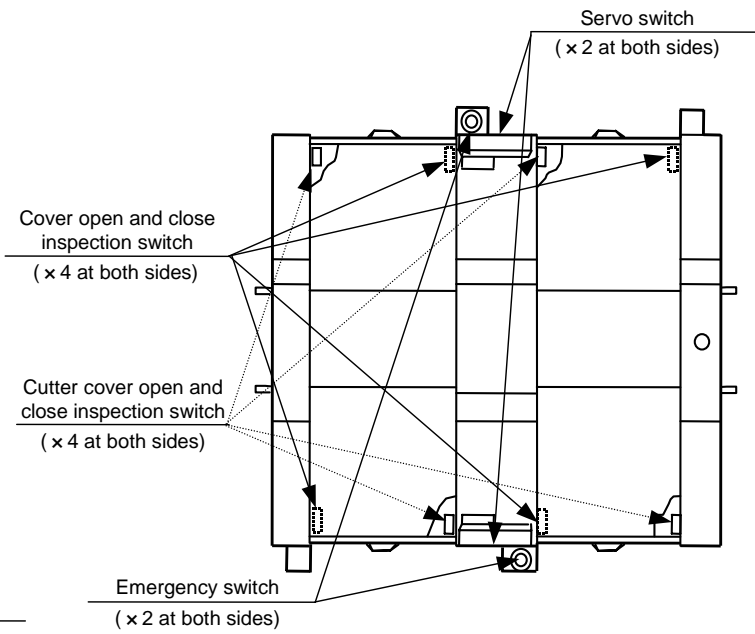
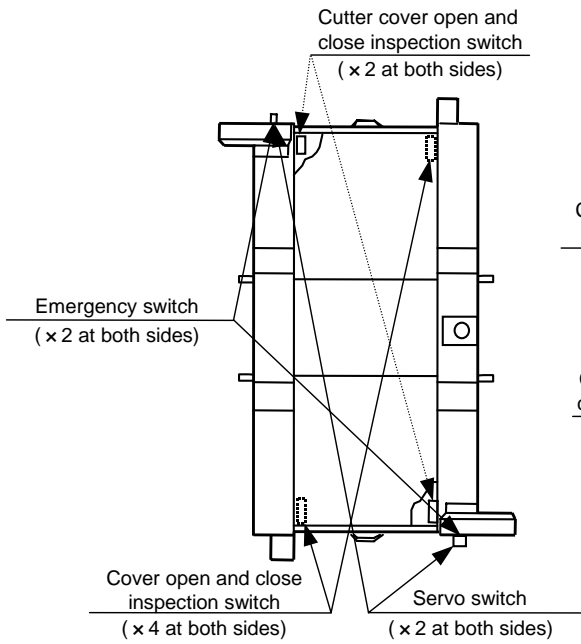

Front view

Front view

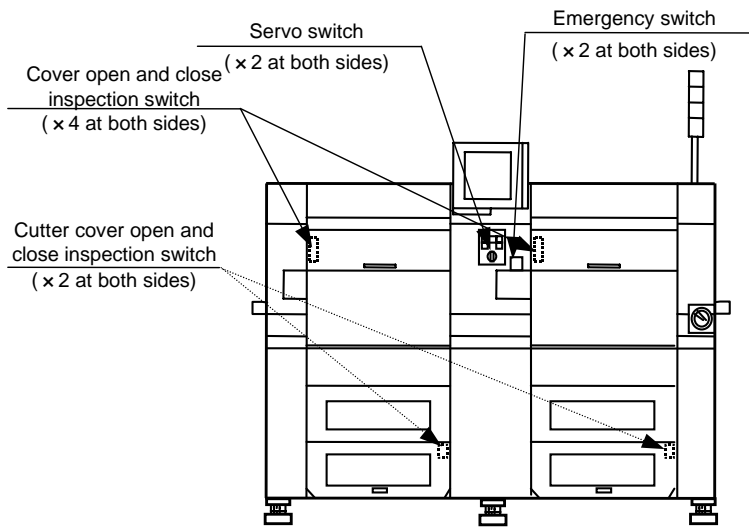
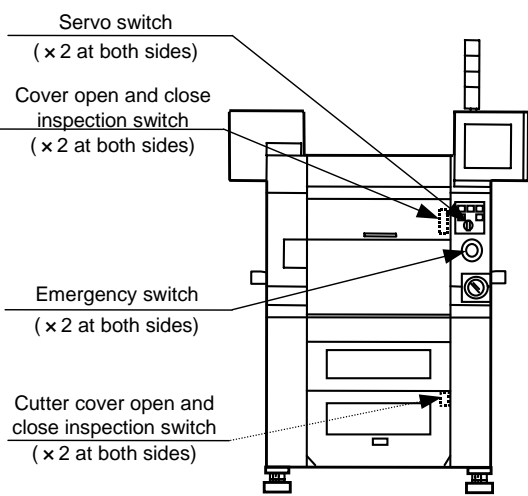

**Remark**

Check enough the separate instruction manual and the warning instruction of devices to operate the machine properly, regardless of operating or stopping it, for the safety use of it.



## 8 - 2 Machine dimensions

CM201-DH

CM202-DH

View from above

View from above

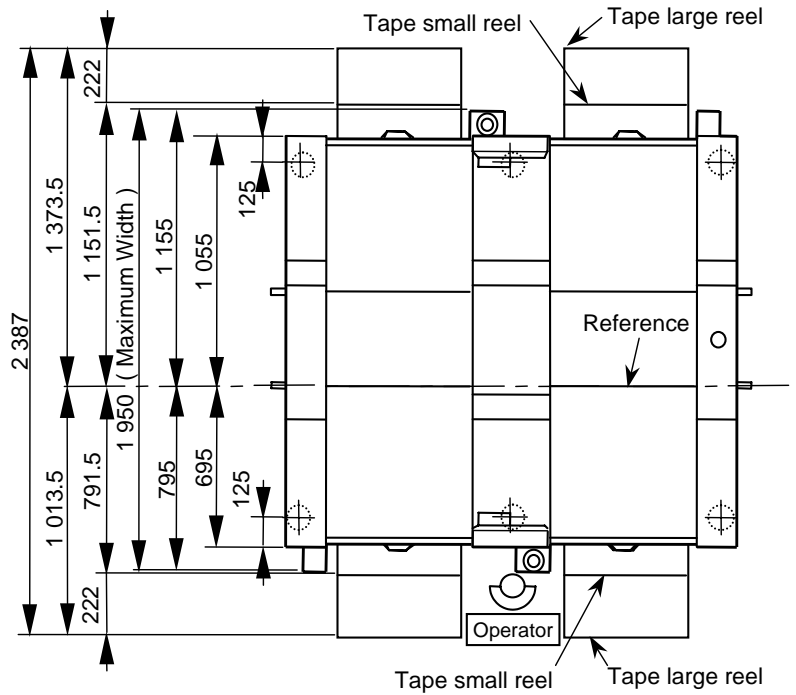
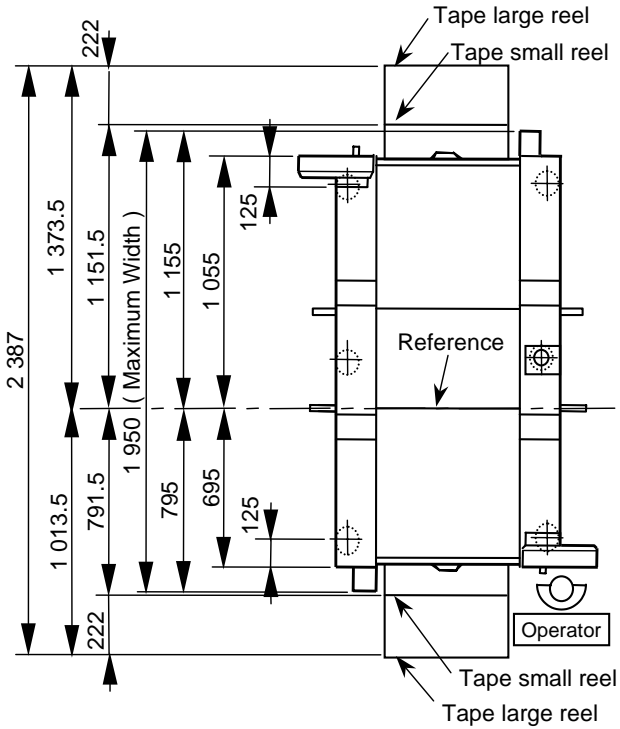

Front view

Front view

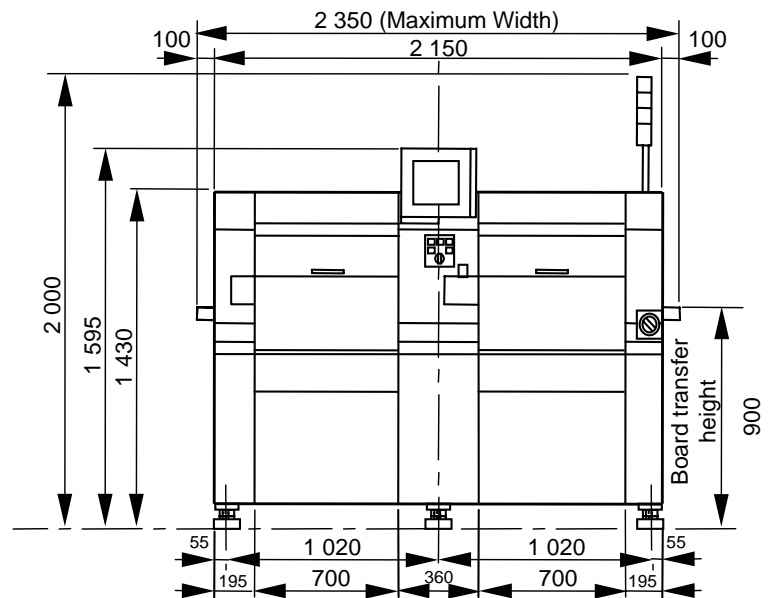
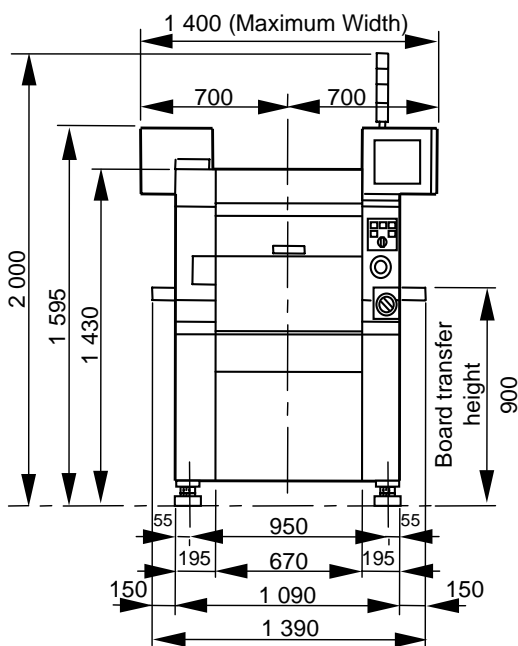

(Unit: mm)



### Remarks

The reduced length of the upper illustration does not precisely match the size of actual machine.

\* The installation dimensions of the CM202-DH are different from those of the CM202-D. So be careful when changing the D type to the DH type.

CM201-DHU

View from above

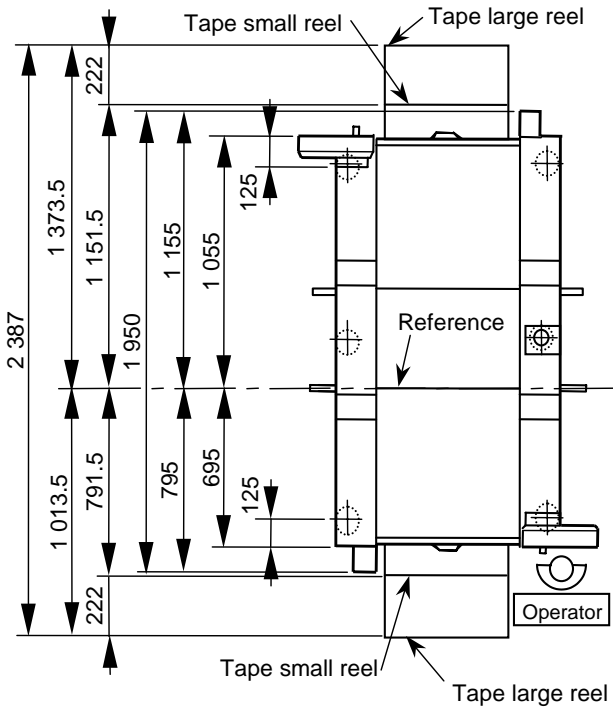

CM202-DHU

View from above

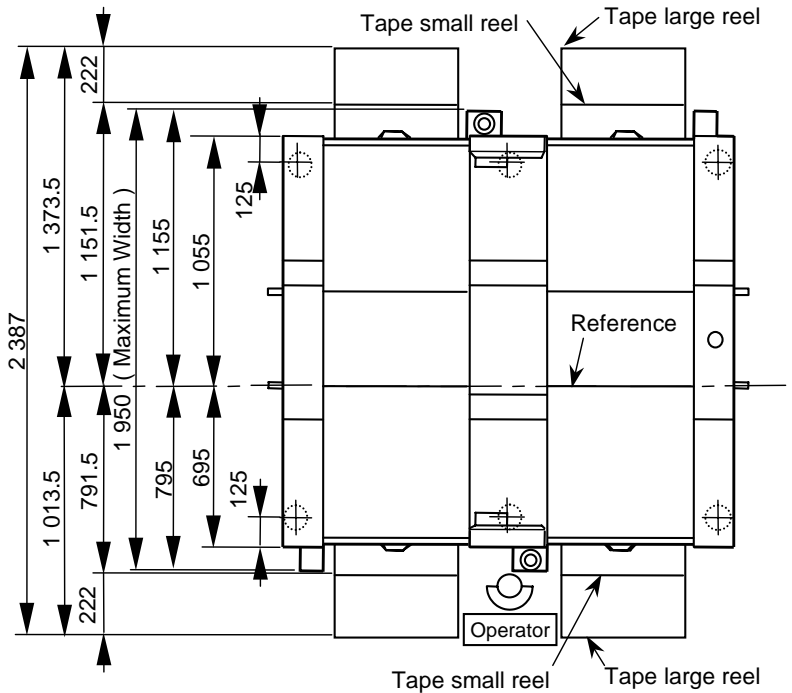

Front view

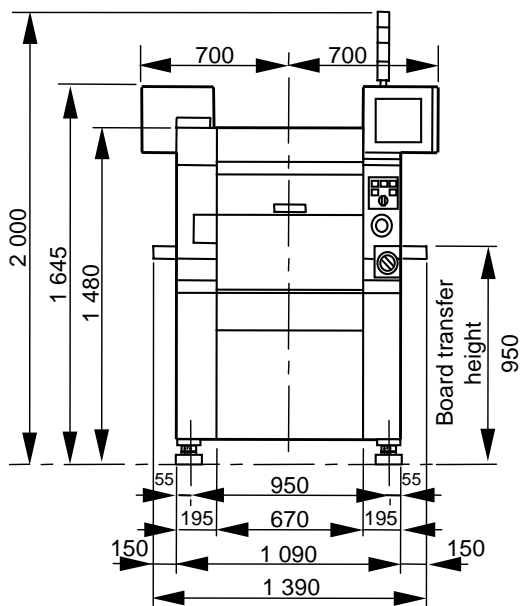

Front view

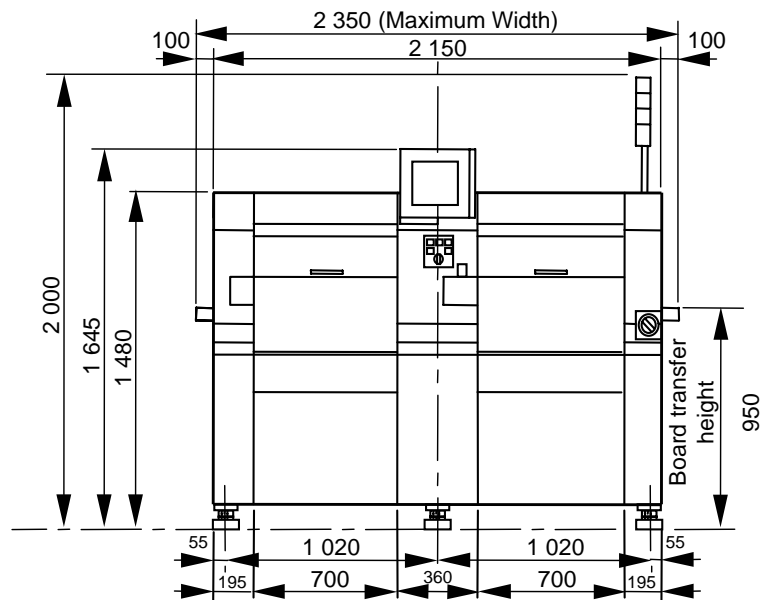

(Unit: mm)



**Remarks**

The reduced length of the upper illustration does not precisely match the size of actual machine.

\* The installation dimensions of the CM202-DHU are different from those of the CM202-DU. So be careful when changing the DU type to the DHU type.

### 8 - 3 Power and air supply parts

#### Air supply part CM201

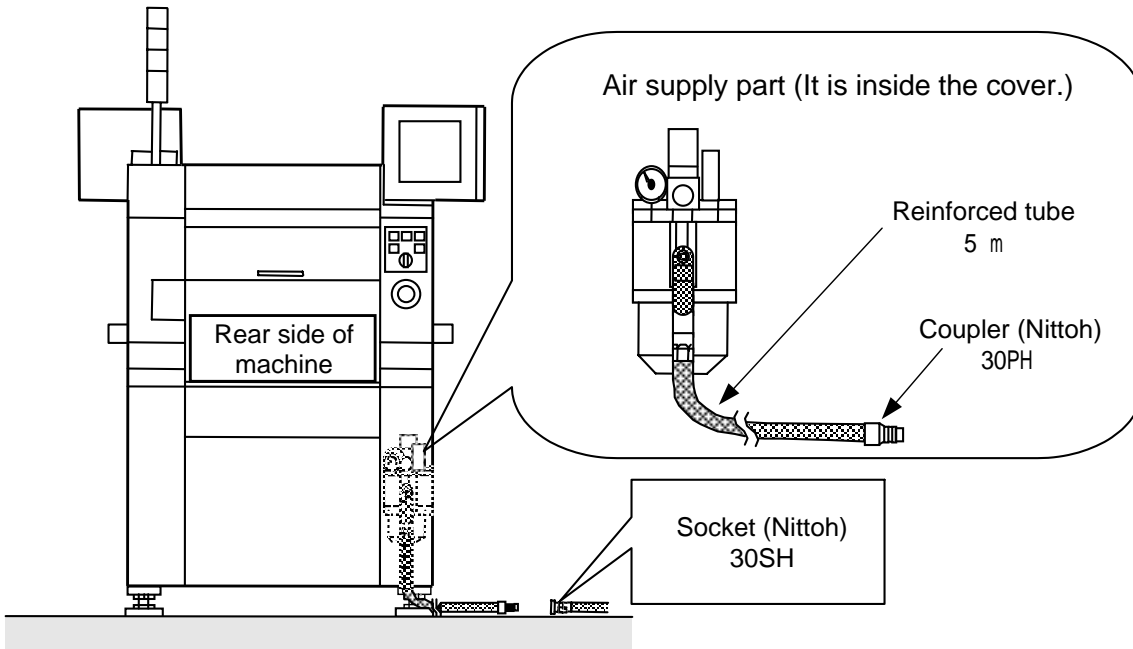

#### CM202

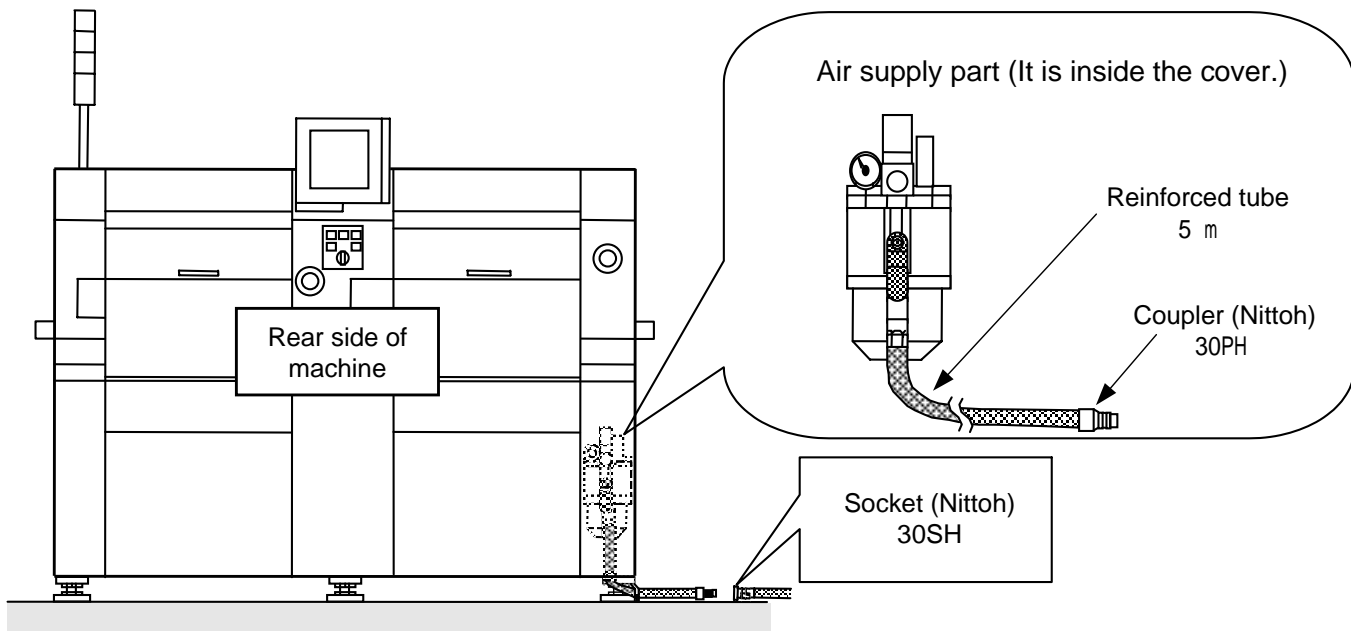

#### Remark

We ask you to prepare the socket yourself.

Power supply part

**CM201/202-DH**

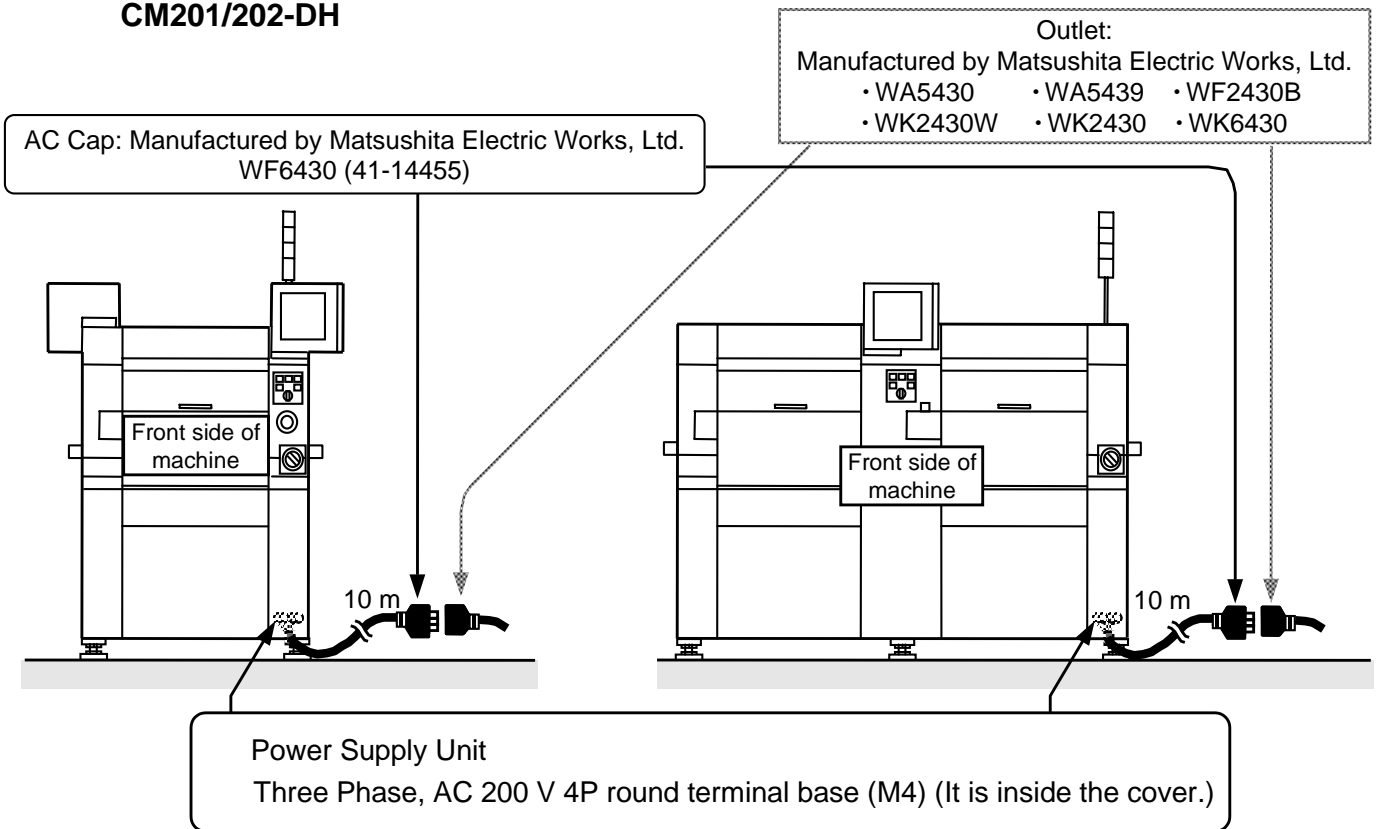

**CM201/202-DHU**

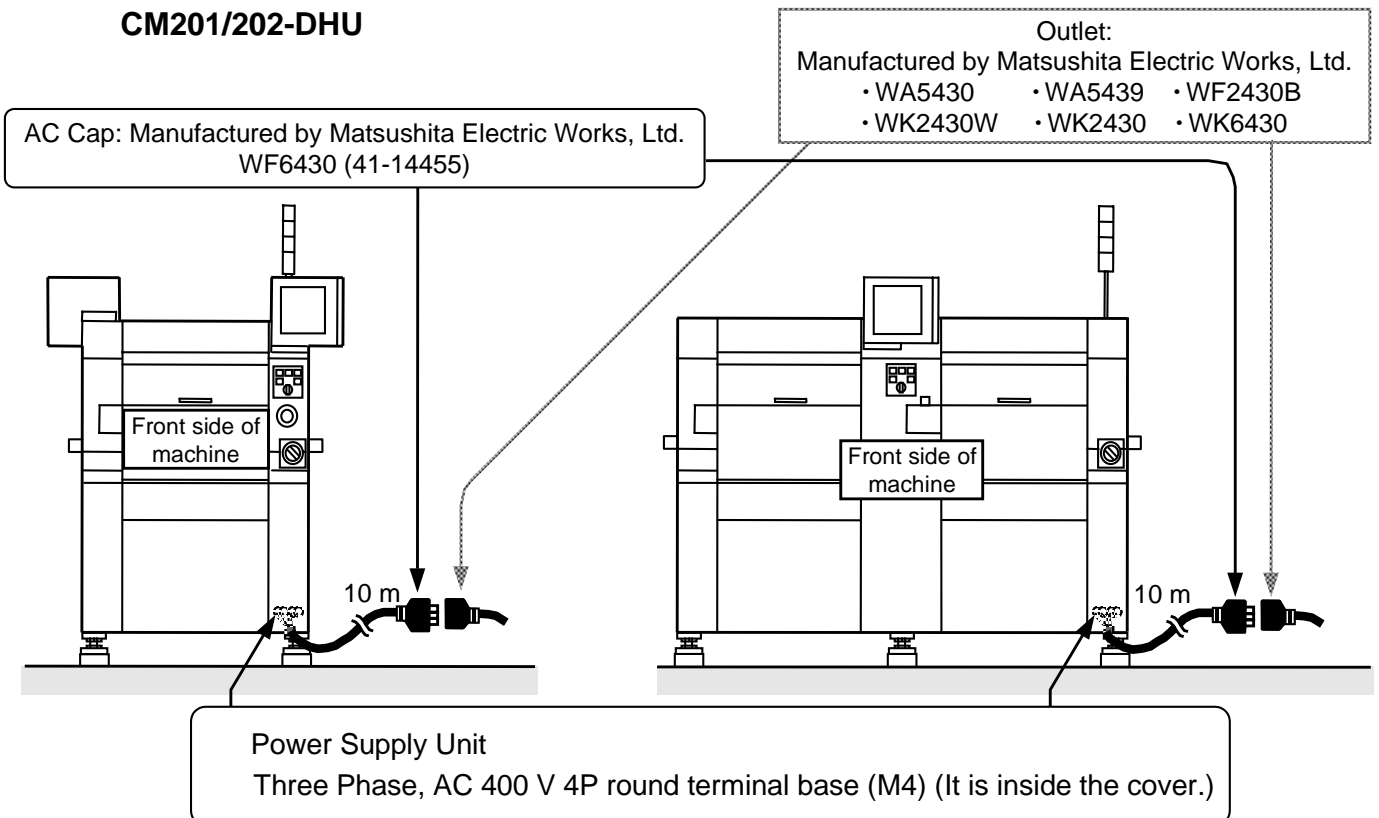

**Remark**

We ask you to prepare the socket yourself.



## Safety Cautions

**To ensure safety when using this equipment, all work should be performed correctly after thoroughly checking the separate Operating Instructions as well.**

Starting on January 1, 1996, products failing to comply with the EC machinery directive and EMC directive may not be brought into or sold in the EC. Some products may be controlled under Foreign Exchange and Foreign Trade Control Laws as one of the strategic products.

The export of this product is subject to the authorization of the government of the exporting country.

When considering the resale or relocation of equipment, please be absolutely sure to contact KME or an authorized dealer.

Technical information contained in this material is for description of representative and applications of the product and must not be interpreted as warranty or granting the license concerning the propriety and other rights of our company and the third party during operation of the product.

### Sales & Service

**Matsushita Electric Industrial Co., Ltd.  
Kyushu Matsushita Electric Co., Ltd.  
FA Division**

441-13, Nagahasu, Tateishi-machi,  
Tosu-city, Saga 841-8585, JAPAN

PHONE 0942-84-2645 ~ 2648

FAX 0942-84-2636

**This document reflects system specifications  
as of February 20, 2002**

Specifications and design are subject to change without notice due to improvements, etc.

Windows NT and MS-DOS are registered trademarks of Microsoft Corporation of the U.S. both in the U.S. and other countries.

**Listening to You . . . Building Tomorrow**